

TRACFINDER RAIL

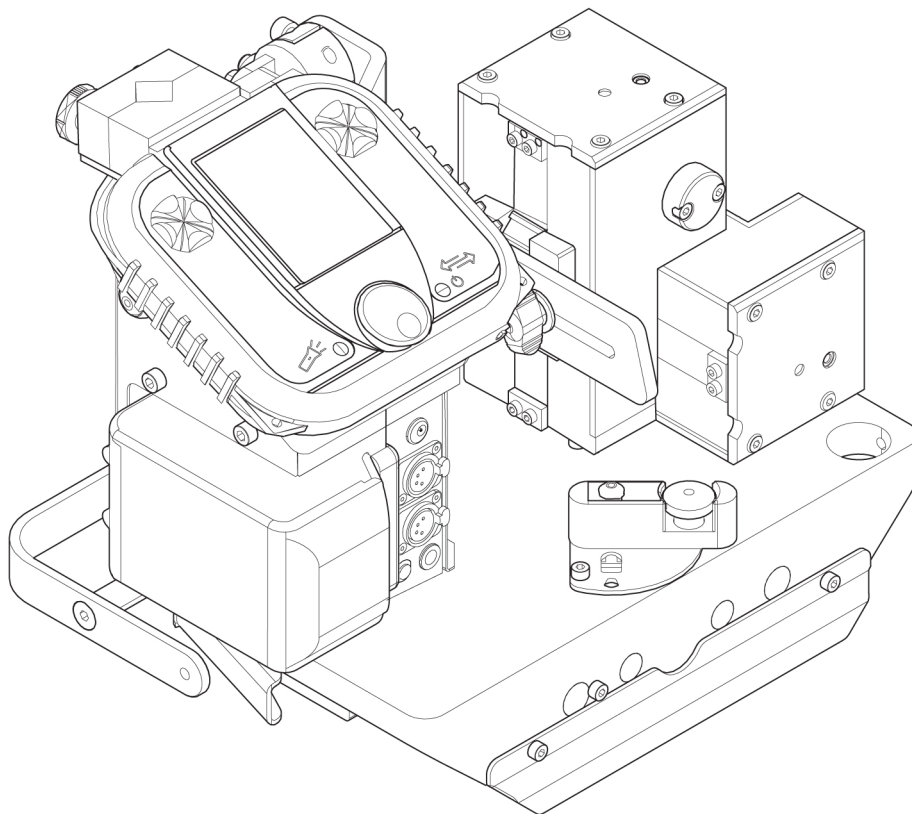

Instruction manual



EU DECLARATION OF CONFORMITY

According to:

The Low Voltage Directive 2014/35/EU; The EMC Directive 2014/30/EU;
The RoHS Directive 2011/65/EU; The Radio Equipment Directive 2014/53/EU

Type of equipment

Welding Tractor

Type designation

CARRIAGE & ACCESSORY from serial number SD524 YY XX XXXX
X and Y represents digits, 0 to 9 in the serial number, where YY indicates year of production.

Brand name or trademark
ESAB

Manufacturer or his authorised representative established within the EEA

Name, address, telephone no:

ESAB AB
Lindholmsallén 9, Box 8004, SE-402 77 Göteborg, Sweden
Phone: +46 31 50 90 00

The following EN standards and regulations in force within the EEA has been used in the design:

EN ISO 12100:2010	Safety of machinery - General principles for design - Risk assessment and risk reduction
EN IEC 60974-5:2019	Arc Welding Equipment – Part 5: Wire Feeders
IEC 60974-10:2020	Arc Welding Equipment - Part 10: Electromagnetic compatibility (EMC) requirements
EN300328 V2.2.2	Wideband transmission systems; Data transmission equipment operating in the 2,4 GHz band; Harmonised Standard for access to radio spectrum
EN301489-1 V2.2.3	ElectroMagnetic Compatibility (EMC) standard for radio equipment and services; Part 1: Common technical requirements
EN301489-17 V3.2.4	ElectroMagnetic Compatibility (EMC) standard for radio equipment and services; Part 17: Specific conditions for Broadband Data Transmission Systems

Additional Information:

Restrictive use, Class A equipment, intended for use in locations other than residential.

By signing this document, the undersigned declares as manufacturer, or the manufacturer's authorised representative established within the EEA, that the equipment in question complies with the safety and environmental requirements stated above.

Place/Date

Gothenburg
2025-11-06

Signature

Peter Burchfield
VP, Global Products



1	SAFETY	5
1.1	Meaning of symbols	5
1.2	Safety precautions	5
2	INTRODUCTION	8
3	TECHNICAL DATA	9
3.1	Dimensions drawing	9
4	INSTALLATION	10
4.1	Description of the rail base	10
4.2	Connecting the torch	11
4.3	Connecting the carriage on rail track	12
4.4	Installing the battery	12
4.5	Recharging the remote control	13
5	OPERATION	14
5.1	Connecting the trigger	14
5.2	Connecting an accessory	14
5.3	Connecting the arc sensor	15
5.4	Turning the carriage ON and OFF	15
6	CONTROL PANEL	16
6.1	Description of the standard tower	16
6.2	Description of the programmable tower and remote control	17
6.3	Description of the standard tower interface	18
6.3.1	Main view	18
6.3.2	Accessing product information	18
6.3.3	Accessing the advance settings menu	19
6.3.4	Programming	20
6.3.5	Programmable mode activated "ON" [P]	21
6.4	Description of remote control panel interface	23
6.4.1	Remote control interface for advanced HMI	23
6.4.2	Carriage jobs	24
6.4.3	Archiving jobs	25
6.4.4	Cycle configuration	26
6.4.5	Cycle forms	26
6.4.6	Welding	27
6.4.7	Plasma cutting	28
6.4.8	Settings	29
6.4.9	Programming	30
6.4.10	Connected axis settings	33
6.4.11	Limits	35
6.4.12	Origin resets	35
6.4.13	Joint teaching	36
6.4.14	Machine configuration	38
6.4.15	Guiding the axes (manual mode)	39
6.4.16	User functions	41
6.5	Starting up, pairing and turning off the remote control	42
6.5.1	Starting up and turning off	42
6.5.2	Pairing the remote control	42
6.5.3	Setting up the buttons	43

TABLE OF CONTENTS

- 6.6 **Advanced carriage configuration** 43
- 6.7 **Software updates** 49
 - 6.7.1 Updating tractor 49
 - 6.7.2 Updating remote control 50
 - 6.7.3 Updating accessory (communication box, axes etc). 52
- 7 **MAINTENANCE** 53
 - 7.1 **Periodic maintenance** 53
 - 7.2 **Rail servicing and replacement instructions** 53
 - 7.3 **Replacing rollers** 55
- 8 **TROUBLESHOOTING** 56
- 9 **ORDERING SPARE PARTS** 57
- ORDERING NUMBERS** 58
- ACCESSORIES** 59

1 SAFETY

1.1 Meaning of symbols

As used throughout this manual: Means Attention! Be Alert!



DANGER!

Means immediate hazards which, if not avoided, will result in immediate, serious personal injury or loss of life.



WARNING!

Means potential hazards which could result in personal injury or loss of life.



CAUTION!

Means hazards which could result in minor personal injury.



WARNING!

Before use, read and understand the instruction manual and follow all labels, employer's safety practices and Safety Data Sheets (SDSs).



1.2 Safety precautions

Users of ESAB equipment have the ultimate responsibility for ensuring that anyone who works on or near the equipment observes all the relevant safety precautions. Safety precautions must meet the requirements that apply to this type of equipment. The following recommendations should be observed in addition to the standard regulations that apply to the workplace.

All work must be carried out by trained personnel well-acquainted with the operation of the equipment. Incorrect operation of the equipment may lead to hazardous situations which can result in injury to the operator and damage to the equipment.

1. Anyone who uses the equipment must be familiar with:
 - its operation
 - location of emergency stops
 - its function
 - relevant safety precautions
 - welding and cutting or other applicable operation of the equipment
2. The operator must ensure that:
 - no unauthorised person is stationed within the working area of the equipment when it is started up
 - no-one is unprotected when the arc is struck or work is started with the equipment
3. The workplace must:
 - be suitable for the purpose
 - be free from drafts
4. Personal safety equipment:
 - always wear recommended personal safety equipment, such as safety glasses, flame-proof clothing, safety gloves
 - do not wear loose-fitting items, such as scarves, bracelets, rings, etc., which could become trapped or cause burns

5. General precautions:

- make sure the return cable is connected securely
- work on high voltage equipment **may only be carried out by a qualified electrician**
- appropriate fire extinguishing equipment must be clearly marked and close at hand
- lubrication and maintenance must **not** be carried out on the equipment during operation



WARNING!

Arc welding and cutting can be injurious to yourself and others. Take precautions when welding and cutting.



ELECTRIC SHOCK - Can kill

- Install and ground the unit in accordance with instruction manual.
- Do not touch live electrical parts or electrodes with bare skin, wet gloves or wet clothing
- Insulate yourself from work and ground.
- Ensure your working position is safe



ELECTRIC AND MAGNETIC FIELDS - Can be dangerous to health

- Welders having pacemakers should consult their physician before welding. EMF may interfere with some pacemakers.
- Exposure to EMF may have other health effects which are unknown.
- Welders should use the following procedures to minimize exposure to EMF:
 - Route the electrode and work cables together on the same side of your body. Secure them with tape when possible. Do not place your body between the torch and work cables. Never coil the torch or work cable around your body. Keep welding power source and cables as far away from your body as possible.
 - Connect the work cable to the workpiece as close as possible to the area being welded.



FUMES AND GASES - Can be dangerous to health

- Keep your head out of the fumes
- Use ventilation, extraction at the arc, or both, to take fumes and gases away from your breathing zone and the general area



ARC RAYS - Can injure eyes and burn skin

- Protect your eyes and body. Use the correct welding screen and filter lens and wear protective clothing
- Protect bystanders with suitable screens or curtains



NOISE - Excessive noise can damage hearing

Protect your ears. Use earmuffs or other hearing protection.



MOVING PARTS - Can cause injuries

- Keep all doors, panels and covers closed and securely in place. Have only qualified people remove covers for maintenance and troubleshooting as necessary. Reinstall panels or covers and close doors when service is finished and before starting engine.



- Stop engine before installing or connecting unit.
- Keep hands, hair, loose clothing and tools away from moving parts.



FIRE HAZARD

- Sparks (spatter) can cause fire. Make sure therefore that there are no inflammable materials nearby
- Do not use on closed containers.



HOT SURFACE - Parts can burn

- Do not touch parts bare handed.
- Allow cooling period before working on equipment.
- To handle hot parts, use proper tools and/or insulated welding gloves to prevent burns.

MALFUNCTION - Call for expert assistance in the event of malfunction.

PROTECT YOURSELF AND OTHERS!



NOTE!

Dispose of electronic equipment at the recycling facility!

In observance of European Directive 2012/19/EC on Waste Electrical and Electronic Equipment and its implementation in accordance with national law, electrical and/or electronic equipment that has reached the end of its life must be disposed of at a recycling facility.

As the person responsible for the equipment, it is your responsibility to obtain information on approved collection stations.

For further information contact the nearest ESAB dealer.

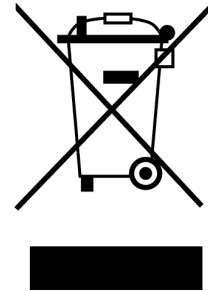

2 INTRODUCTION

The device is an autonomous carriage on a guide rail that has been specifically designed for mechanised semi-automatic welding in all positions. The TRACFINDER RAIL is designed to move along a fixed track. It carries a welding torch along with it and ensures a consistent linear motion.

The carriage is usually equipped with gears and rollers that fit precisely onto the rail. This carriage is designed to function with tower and interface. The device is equipped with a control unit intended for use by a single operator at a time.

Main features of TRACFINDER RAIL:

- Light and durable.
- Automated movement.
- It is easy to use and set up.

3 TECHNICAL DATA

TRACFINDER RAIL	
Dimension (L × W × H)	345 × 220 × 225
Weight	7 Kg
Power supply	18 Vdc, 5 Ah
Operational autonomy for a 5Ah, 18V battery	From 8 to 20 hours*
Recharging time for a 5Ah, 18V battery	45 min
Carriage speed for a 5Ah, 18V full battery	From 1 to 180 cm/min
Temperature	-5°C (23 °F) and 60 °C (140 °F)
Noise emission (LPA)	< 70 dB (A)
Remote control autonomy	8 hours
Enclosure class	IP43

* Depending on configuration

3.1 Dimensions drawing

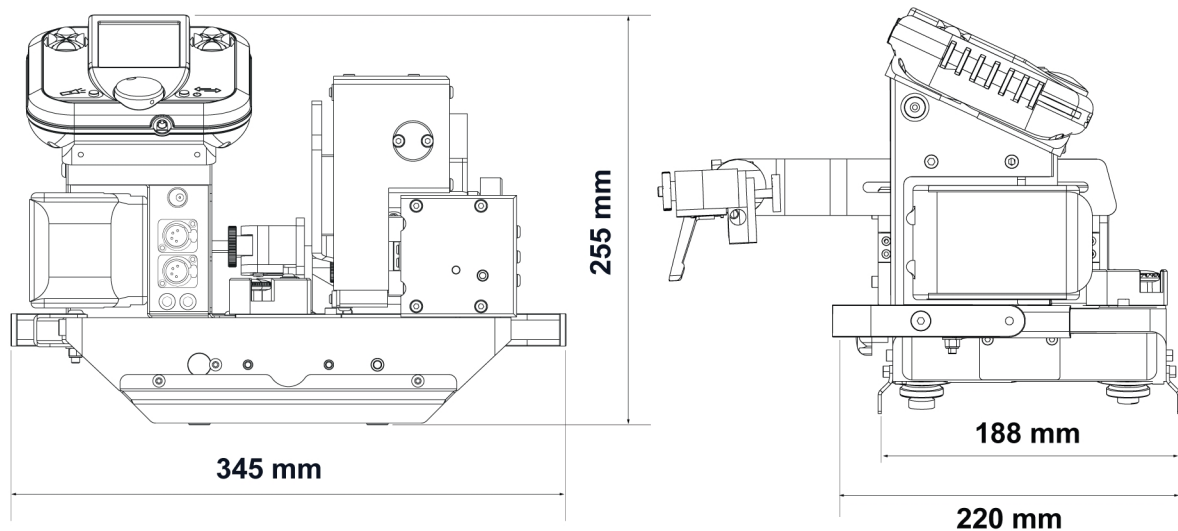

4 INSTALLATION



CAUTION!

This product is intended for industrial use. It is the user's responsibility for adequate precautions.

4.1 Description of the rail base

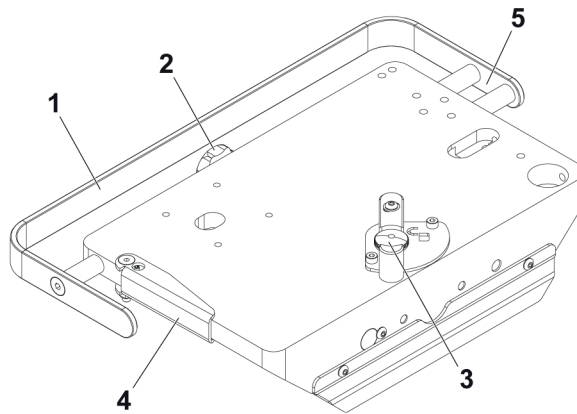

- **Handling handle (1):** ergonomically lifts the carriage in order to move it.
- **Selection dial (2):** for directing the guide rollers when you're positioning the soft rail over a curved part. The central position corresponds to the support on a flat surface.
- **Locking handles (3):** for locking/unlocking the guide rollers on the guide rail to keep the carriage on the rail.
- **Engine clutch lever (4):** for manually rolling the carriage on the rail.
- **Reinforced area for slinging (5):** for slinging the carriage for added safety in the event of lost magnetic or pneumatic adherence of the rail.

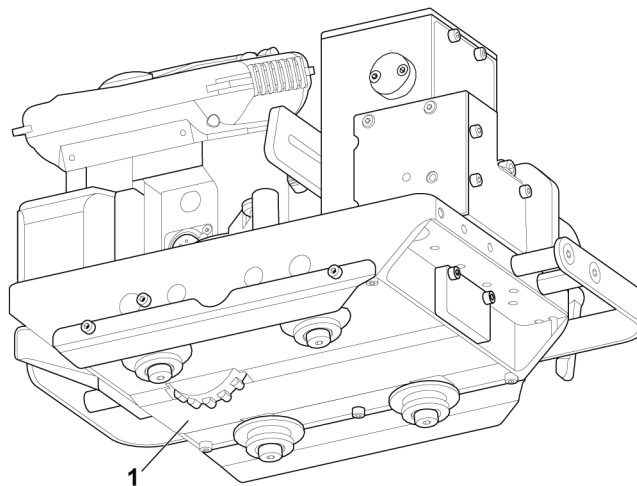

- **Casing (1):** checks, repairs and services the carriage equipment.

4.2 Connecting the torch

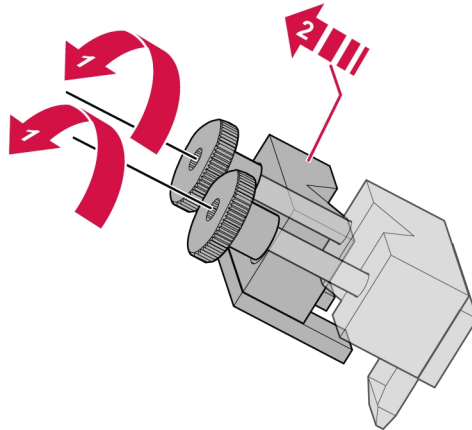

- 1) Loosen the threaded nuts around the torch neck.
- 2) Remove the single jaw.

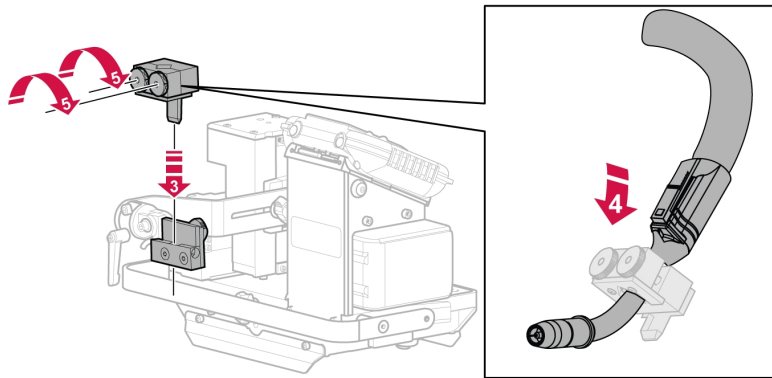

- 3) Insert the tool mount into the carriage.
- 4) Insert the torch between the two jaws.
- 5) Tight the bolts back to the jaws.



WARNING!

The jaw must be oriented downwards to enable detection with the arc sensor.

4.3 Connecting the carriage on rail track

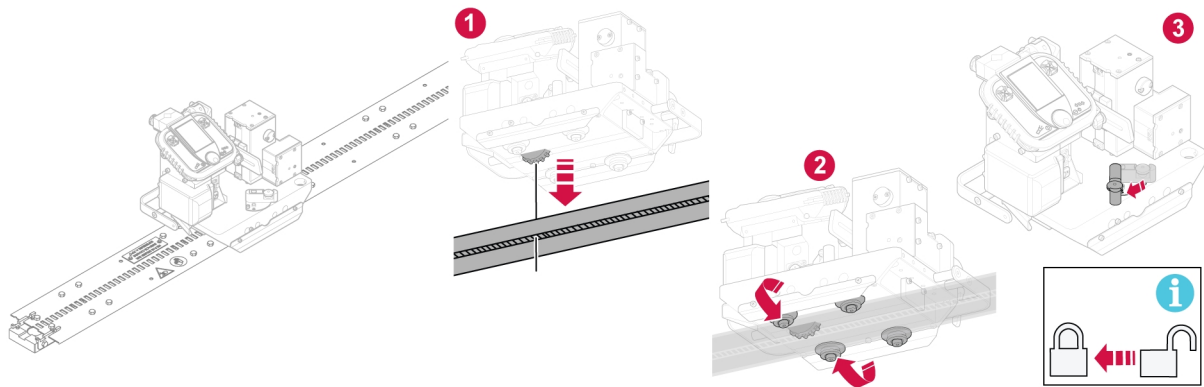

- 1) While placing the carriage on the track, check whether the gear is correctly mounted on the track.
- 2) Support the guide rollers on the rail track.
- 3) Lock it by turning the handle.

4.4 Installing the battery

The carriage is designed to function with an 18V Li-ion battery or with an optional external power supply.

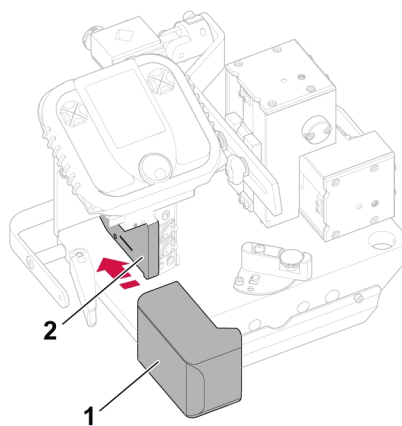

- 1) Unclip the battery (1) by pressing the unlock button before removing it from the mount (2).



WARNING!

It is important to thoroughly clean the mount using compressed air or a clean cloth before inserting a battery. Risk of malfunction.

- 2) Insert the battery (1) in its mount (2) until it reaches the holding clips.



WARNING!

In the event of a defective battery, it must be taken in charge by a selective collection system in accordance with the regulations of the country and the European directive so that it can either be recycled or dismantled in order to reduce any impact on the environment.

4.5 Recharging the remote control

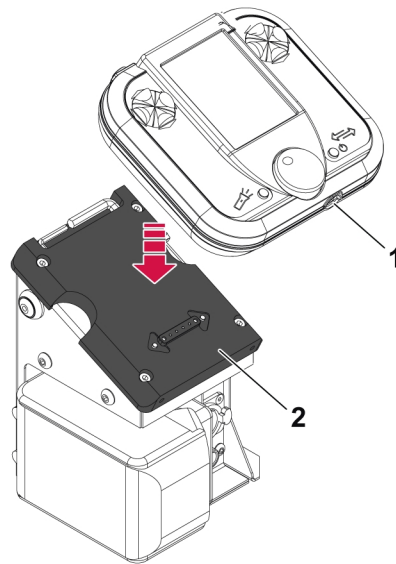

The remote control is powered by an internal battery. There are two ways to recharge it.

1) Recharge the internal battery by either:

- When not in use, via a charger on a 230V socket connected to a charging port (1).
- When in use, by placing the remote control on its charging base on the remote-controlled tower (2).



WARNING!

If the remote control goes off due to low battery power in mid-cycle, the cycle will continue. The remote control can then be placed on the charging base to finish the cycle.



NOTE!

The remote control is held on the charging base by magnets to stop it from falling.

5 OPERATION



CAUTION!

This product is intended for industrial use. It is the user's responsibility for adequate precautions.

5.1 Connecting the trigger

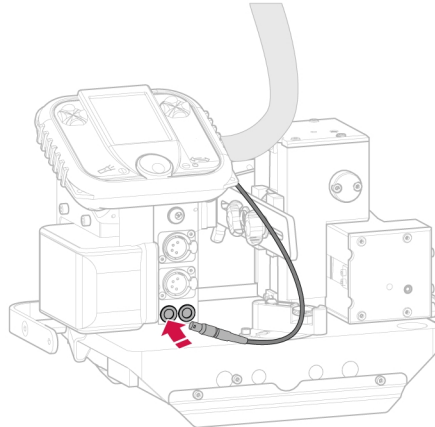

- 1) Connect the trigger cable on the control port.
- 2) The welding arc is synchronized with the movement of the carriage, activate it by pressing the start cycle button on the carriage.

5.2 Connecting an accessory

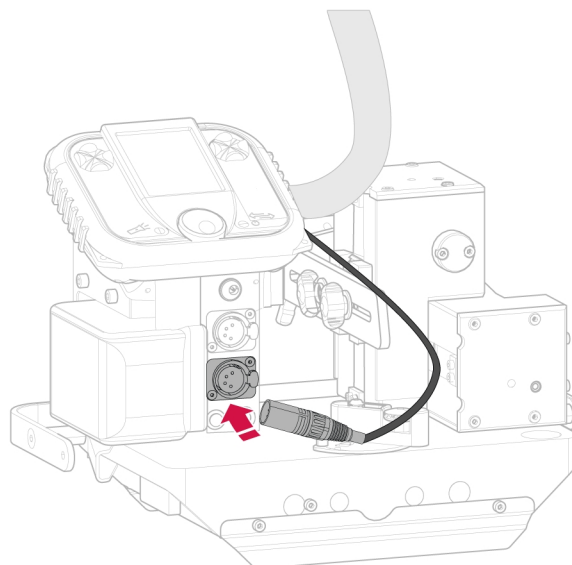

- 1) Connect the accessory cable to corresponding port. It is used for connecting an accessory (motorized axis, communication box, etc).

5.3 Connecting the arc sensor

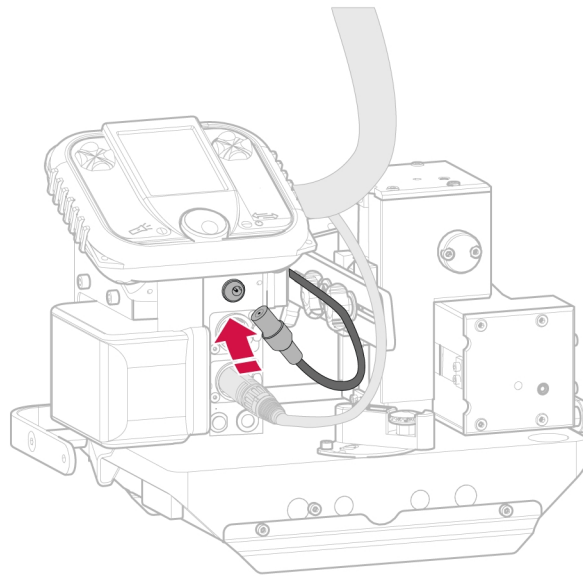

- 1) Connect the welding arc sensor cable to the socket.
- 2) The carriage movement is then synchronized with the arc, initiate it by pulling the torch trigger.

5.4 Turning the carriage ON and OFF

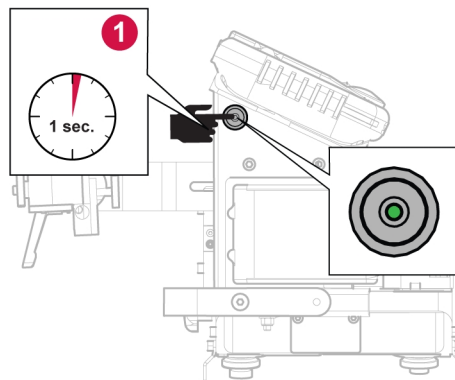

Starting up the carriage

- 1) Press the button to turn ON the device. The LEDs and screen turn on.

Shutting down the carriage

- 1) Press and hold (3 seconds) the start button to turn off the device. The LEDs and screen turn off.

6 CONTROL PANEL

6.1 Description of the standard tower

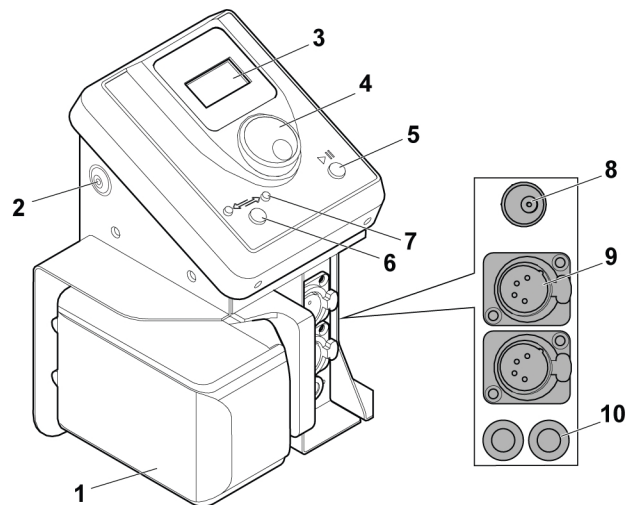

- **Battery (1):** powers the device. The device is designed to function at 18V DC (3A) with a Li-Ion battery (5Ah/h by default) or an external power supply.
- **Luminous ON/OFF button (2):** for turning the device on or off. There is a luminous indicator light to show if the device is on.
- **Screen (3):** for configuring and controlling the device.
- **Selection dial/clicker (4):** for browsing through the menus and selecting the different operation settings.
- **Cycle start / pause button (5):** for launching the cycle or pausing it.
- **Change direction button (6):** for changing the direction of movement of the carriage.
- **Directional indicator lights (7):** for displaying the direction of the carriage. The LED blinks when the cycle is underway.
- **Welding arc sensor socket (8):** for connecting a welding arc sensor, located by the torch support. The carriage's movement is then synchronised with the arc, which is launched using the torch trigger.
- **Accessory port (9):** for connecting an accessory (runner, sensor, lamp, etc).
- **Torch trigger port (10):** for connecting a trigger control cable to the torch. The welding arc is then synchronised with the carriage movement, which is triggered by the start cycle button located on the console.

6.2 Description of the programmable tower and remote control

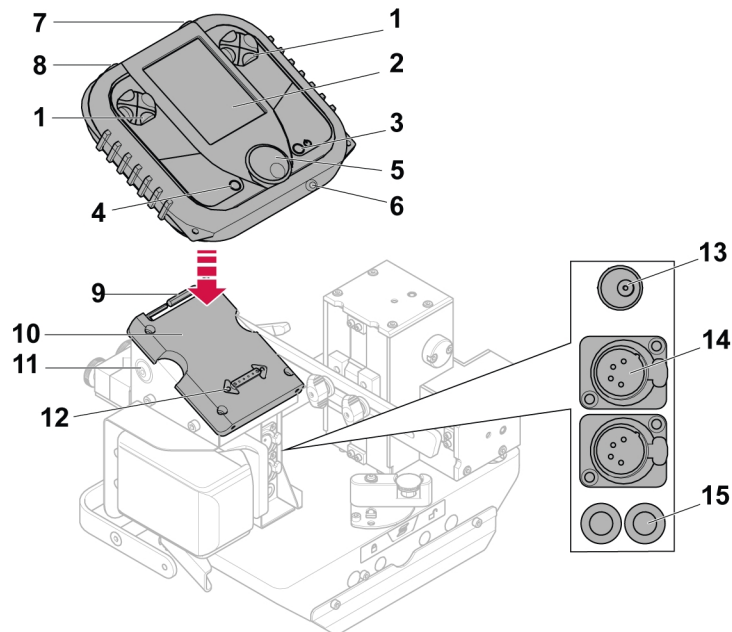

- **Direction arrows (1):** modifies the different device settings.
- **Screen (2):** displays the different menus and settings for the device.
- **Ignition and direction change button (3):** used to switch on the remote control. On the main page, a short press opens the oscillation page (if enabled); a long press changes the direction of carriage movement. On configuration pages, returns you to the previous page.
- **“Light” button (4):** turns on the light located on the rear side of the remote control.
- **Selection dial/clicker (5):** lets you navigate through the menus and selecting the different operation settings.
- **Charging socket (6):** connects a charger to recharge the remote control.
- **Right-hand configurable trigger (7):** by default, for launching the cycle (= cycle start).
- **Left-hand configurable trigger (8):** by default, for launching a test cycle without moving the carriage and without starting the arc (= pre-cycle).
- **Tools (9):** Two Allen keys are provided for adjusting mechanical carriage elements.
- **Pairing and charging base (10):** for housing, charging and pairing the remote control.
- **Luminous ON/OFF button (11):** for turning the carriage on and off. A luminous indicator light shows if there is power to the device.
- **Directional LEDs (12):** with the remote control withdrawn, the two LEDs indicate the direction that the carriage is moving in.
- **Welding arc sensor socket (13):** for connecting a welding arc sensor, located by the torch support. The carriage’s movement is then synchronised with the arc, which is launched using the torch trigger.
- **Accessory port (14):** for connecting an accessory (runner, sensor, lamp, etc).
- **Torch trigger port (15):** for connecting a trigger control cable to the torch. The welding arc is then synchronised with the carriage movement, which is triggered by the start cycle button located on the console.

6.3 Description of the standard tower interface

6.3.1 Main view

This page can be accessed after switching on the truck by pressing the start button ("*Description of the standard tower*", page 16) located on the side of the tower.

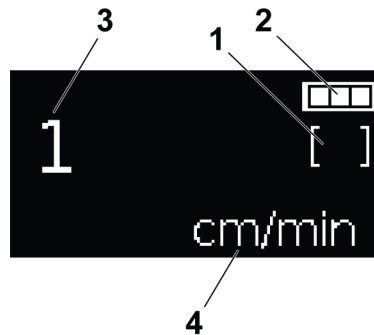

- Carriage status (1)
 - []: Programmable mode deactivated
 - [P]: Programmable mode activated



NOTE!

The programming modes may vary depending on the carriage model.

- Battery level (2)
- Welding speed display (3), can be modified in cycle:
The selection of the number of decimal places after the point can be configured.
- Welding speed unit (4).



NOTE!

In vertical positions and with a certain mass on-board, the distance covered may be different from the guidelines.

6.3.2 Accessing product information

This page can be accessed by holding the dial ("*Description of the standard tower*", page 16) and holding it down for 2 seconds when the ESAB logo is displayed when the carriage is turned on.

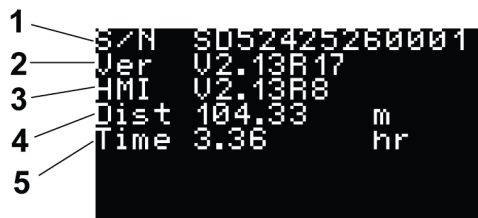

- ESAB serial number (1)
- Carriage version (2)
- Interface version (3)
- Distance covered (4)
- Under tension counter (5): increment of time from the device being powered on (in hours).

6.3.3 Accessing the advance settings menu

This page can be accessed by holding the dial ("*Description of the standard tower*", page 16) and on startup and keeping it held down after the product information screen appears, until "Password" is displayed, then release.

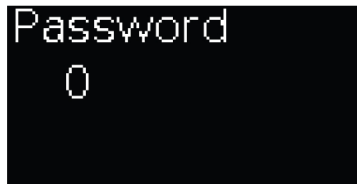

- Enter the password (via the dial):
 - Client: 73

Then click on the dial to access the advanced settings menu:

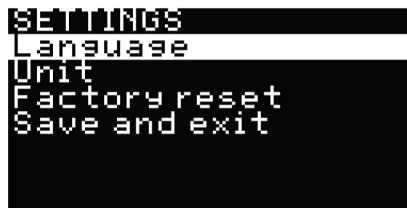

- You select the desired configuration via the dial, then click to access the selection.
- You select the value using the dial, then you click to confirm your selection by returning to the menu page.
- When you have finished, click on one of the two buttons ("*Description of the standard tower*", page 16) to save and return to the main interface view.
- Accessible settings:
 - Reduction 1
 - Increment: 1
 - Min: -10000
 - Max: 10000

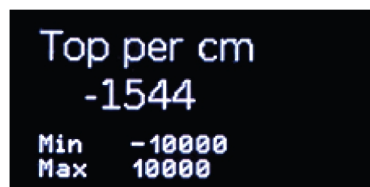

TRACFINDER RAIL carriage reduction table:

Version	"Top per cm"
Rail R: 588	-1544



WARNING!

If these settings are changed, the maximum permissible speed must also be changed.

- Reduction 2: in the case of a TRACFINDER RAIL trolley, the value is 0.
- Max speed (in cm/min or in inch/min) (speed corresponding to the "non-welding" speed):
 - Increment: 0.1
 - Min: 0.1
 - Max: 1000.0

Version	"Top per cm"
Rail R: 588	Max: 200.0 (if cm/min) / 80.0 (if inch/min)

```

Max speed
 180.0 cm/mn
Min  0.1
Max 1000.0

```

- Sheet metal sensor: only for TRACFINDER WHEEL type carriage.
- This option prevents the carriage movement when a magnetic metal surface is no longer detected under the base.
- Language:
 - Fr = 0
 - En = 1
- Unit: to select the different units of measurements.

```

METRIC
1 cm/min
0.1 cm/min
1 inch/min
0.1 inch/min
0.05 inch/min

```

- Factory reset: to restore the software's factory settings.

```

Factory reset
OFF

```

- Click on one of the two buttons (["Description of the standard tower"](#), page 16) to save and return to the main interface view.

6.3.4 Programming

This page can be accessed by clicking on the dial (["Description of the standard tower"](#), page 16).



When you press the dial, you're taken to the "Programming" page (1). Click on the dial to select the programming mode.

- "ON" Programming (1): the trigger cable must be connected to a welding power source in 2 Stroke (2T) mode.
- "OFF" Programming (2): the welding power source is in 4-stroke mode (4T). The carriage start can be controlled manually by the welder (pressing the "on" button) or automatically by the torch arch detection (if the sensor is connected and selected).

To switch from one of the options to another, simply turn the dial. Then, confirm by clicking on the wheel.

- [P]: Programmable mode activated
- []: Programmable mode deactivated

6.3.5 Programmable mode activated “ON” [P]

By selecting the “ON” programming mode (*“Programming”*, page 20).

Turn the dial to navigate through the various adjustment options.

- Delay time of the welding control, before the forward movement of the carriage during the defined time.



Click on the icon to change the following parameter:

- Delay time before welding (in seconds): 3.0
 - Increment: 0.1
 - Min: 0.1
 - Max: 3.0
- Welding length (length of welding at a speed preconfigured in the main view).

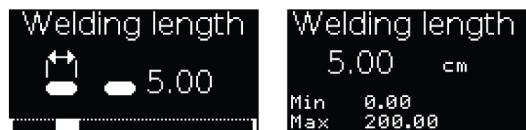

Click on the icon to change the following parameter:

- Welding length (in cm or in inch depending on the setting selected): 5.00
 - Increment: 0.01 / 0.1 / 1 (depending on the setting chosen)
 - Min: 0.00
 - Max: 200.00
- Burn back (in programmable mode and at the end of the welding length, the carriage reverses from the defined value)



Click on the icon to change the following parameter:

- Burn back (in cm or in inch depending on the setting selected): 3.0
 - Increment: 0.1
 - Min: 0.0
 - Max: 10.0

Arc burn back (Activate or deactivate welding during the “Burn back”).



Click on the icon to change the following parameter:

- ON = 1: the “trigger” relay exit is active during the crater return.
- OFF = 0: the “trigger” relay exit is inactive during the crater return.
- Post-weld timer, continues the forward movement of the carriage for a defined time after weld end.



Click on the icon to change the following parameter:

- Delay time after welding (in seconds): 3.0
- Increment: 0.1
- Min: 0.1
- Max: 3.0
- Non-welding length (forward movement without welding at max speed (with acceleration / deceleration ramp)).



Click on the icon to change the following parameter:

- Length excluding welding (in cm or in inches depending on the setting chosen): 5.00
- Increment: 0.01 / 0.1 / 1 (depending on the setting chosen)
- Min: 0.00
- Max: 200.00

- Repetition (number of repetitions of the programmed cycle (welding / non-welding)). Singularity if the value is equal to 0 = the repetition is infinite until the device is stopped by pressing the red button (*"Description of the standard tower"*, page 16).



Click on the icon to change the following parameter:

- Repetition
 - Increment: 1
 - Min: 0
 - Max: 99
- Digit:



Click on the icon to change the following parameter:

- Number of decimal places after the point on the display:
 - 0 = 0
 - 1 = 0.0
 - 2 = 0.00
- Deleting cycles:

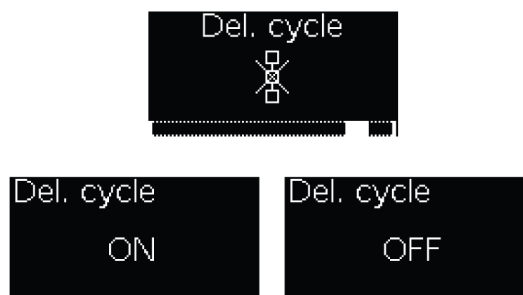

Click on the icon to delete the cycle.

6.4 Description of remote control panel interface

6.4.1 Remote control interface for advanced HMI

The menu can be accessed by clicking the selection dial (*"Description of the programmable tower and remote control"*, page 17). The dial is used to move through the different icons. The menu name is displayed at the bottom of the screen.

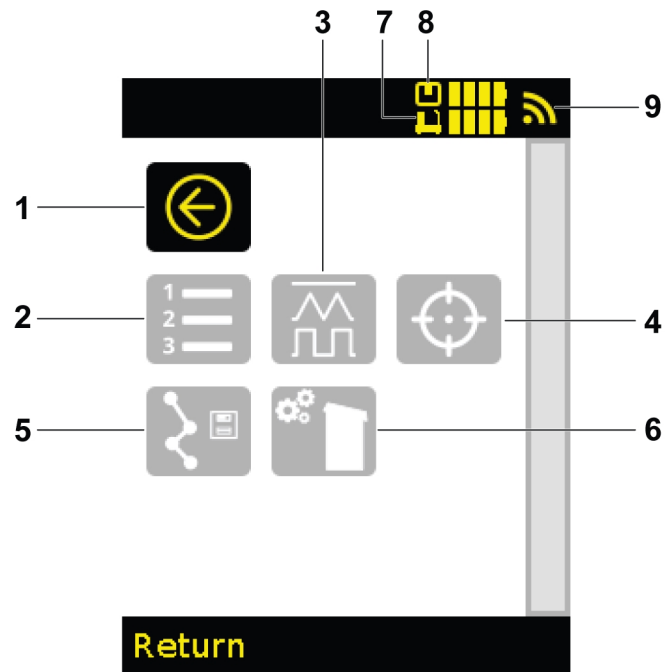

- **Back (1):** takes you back to the previous screen.
- **Jobs (2):** for accessing the job management menu.
- **Cycle configuration (3):** used to access the configuration of welding cycles.
- **Reset (4):** reset one or all of the axes on the carriage.
- **Path recording (5):** for learning points.
- **Machine configuration (6):** displays the software and equipment information for the carriage and accessories.
- **Battery (7 and 8):** displays the carriage battery (7) and remote control (8) charge level.
- **Signal (9):** displays the reception quality for the signal emitted by the tower.

6.4.2 Carriage jobs

This page can be accessed by selecting the "Jobs" icon (1) the menu. The "Jobs" page is used to manage jobs by saving the setting linked to the movements of the carriage and connected axes.

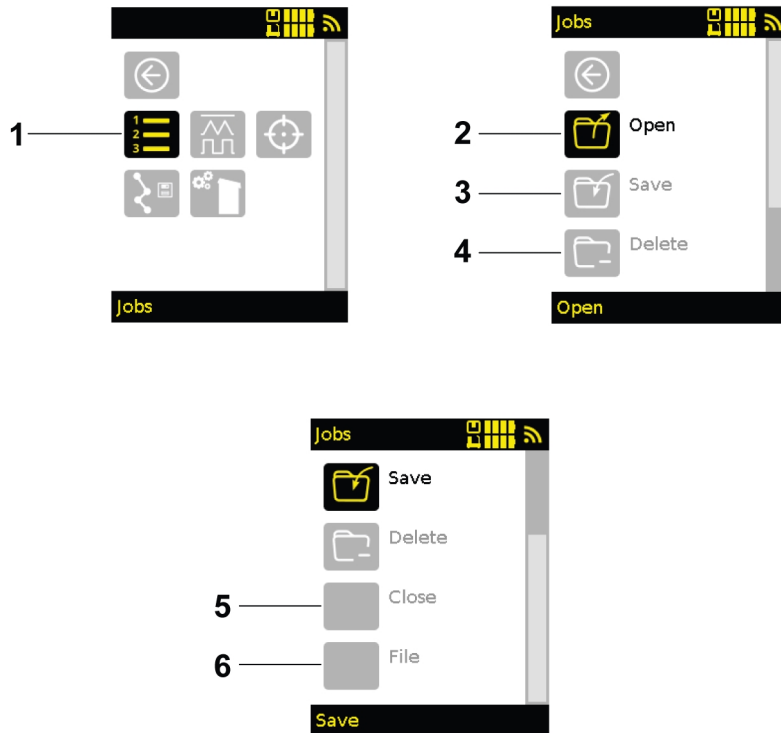

- **Open (2):** loads a job saved in the carriage's memory.
- **Save (3):** saves the job corresponding to all of the settings accessible in the carriage memory.
- **Delete (4):** deletes a saved job from the carriage's memory.
- **Close (5):** closes a job (deletes the name of the active job indicated at the top of the main view).
- **File (6):** grant access to the save job sub-menu.

6.4.3 Archiving jobs

Archived jobs (or jobs to be archived) can be accessed by selecting the "File" icon (1) on the "Jobs" page.

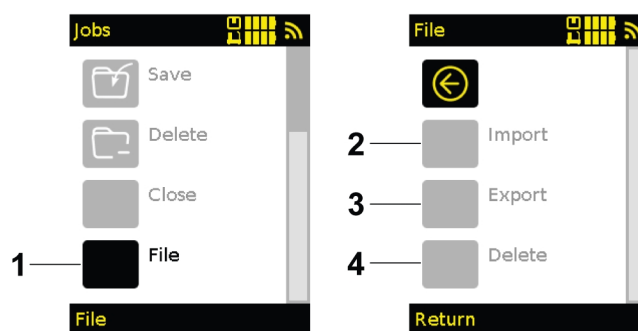

Archiving lets you transfer jobs from one carriage to another, using the remote control for storage:

- **Import (2):** saves all of the carriage jobs to the remote control memory.
- **Export (3):** displays when a back-up has been carried out, and loads the jobs stored in the remote control into carriage.



WARNING!

The jobs currently in the carriage will be overwritten.

- **Delete (4):** delete the jobs saved in the remote control.

6.4.4 Cycle configuration

This page can be accessed by selecting the “Cycle configuration” icon (1) in the menu.

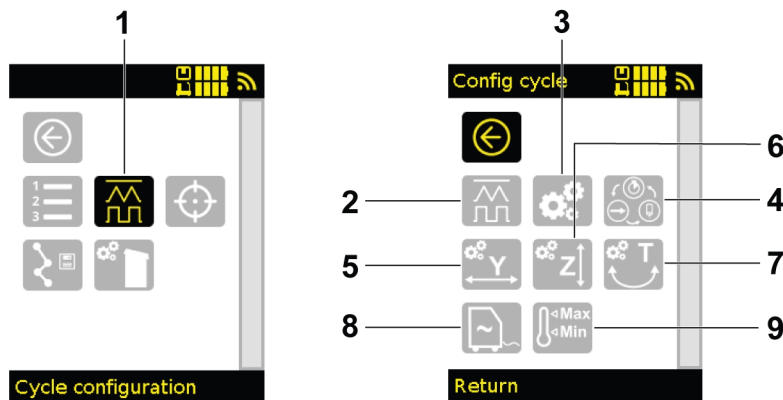

The “Config cycle” page provides access to the configuration of welding cycles in order to characterise the feed forms, the settings linked to the type of equipment, the configuration of the axes connected to the equipment or the programming of a welding sequence.

The “Config cycle” page displays icons according to the equipment connected. The above page corresponds to a carriage equipped with 3 axes (Y, Z and T) and a communication box connected to a power source. If the Y axis is disconnected, the icon (6) corresponding to the Y axis will disappear.

In the case of a revenue record ("*Carriage jobs*", page 24 and "*Archiving jobs*", page 25), all the settings in the “Cycle configuration” menu will be saved in the job.

- **Cycle form (2):** used to access the different welding and oscillation modes.
- **Setting (3):** give access to the generic cycle settings.
- **Cycle programming (4):** used to create a welding programme using various tools.
- **Transverse axis configuration (5):** used to configure the settings of the transverse axis (Y axis) with or without oscillation.
- **Vertical axis configuration (6):** used to configure the settings of the vertical axis (Z axis) and the height servo control.
- **Angular axis configuration (7):** used to configure the settings of the angular axis (T axis) with or without oscillation.
- **Power source settings (8):** used to configure the power source settings (only visible when a communication box is connected).
- **Limits (9):** used to set limits for different settings.

6.4.5 Cycle forms

This page can be accessed by selecting the “Cycle form” icon (1) on the “Cycle setup” page.

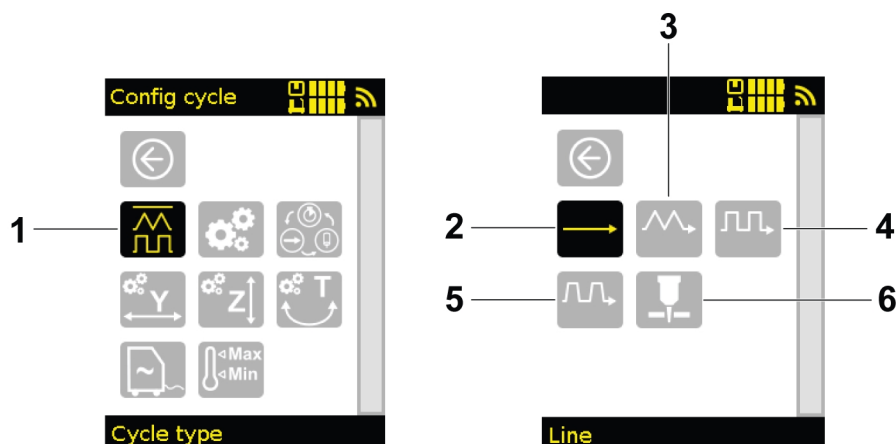

- **Taut or straight cord (2):** welding mode for making one-piece seams without oscillation.

The following oscillation modes are available if the carriage has at least one electric Y runner or T pendulum oscillator. If both are connected, select which axis(s) you wish to oscillate with.

- **Triangle step oscillation (3):** first synchronized oscillation mode. The carriage moves while the axis of oscillation is crossed. If a timeout is set, the carriage stops during the oscillation.
- **Square step oscillation (4):** second synchronized oscillation mode. The carriage moves forward during the timeout; therefore, along the bevel edges. During crossing, the carriage does not move forward.
- **Trapeze step oscillation (5):** basic oscillation mode. The sweeping is not synchronised with the carriage movement, which remains constant.
- **Plasma (6):** this mode enables plasma cutting via a trigger cable connected between the turret connection and the plasma source.

6.4.6 Welding

This page can be accessed after selecting a cycle form ("*Cycle forms*", page 26). On the main page, change pages to access the "Welding" display.

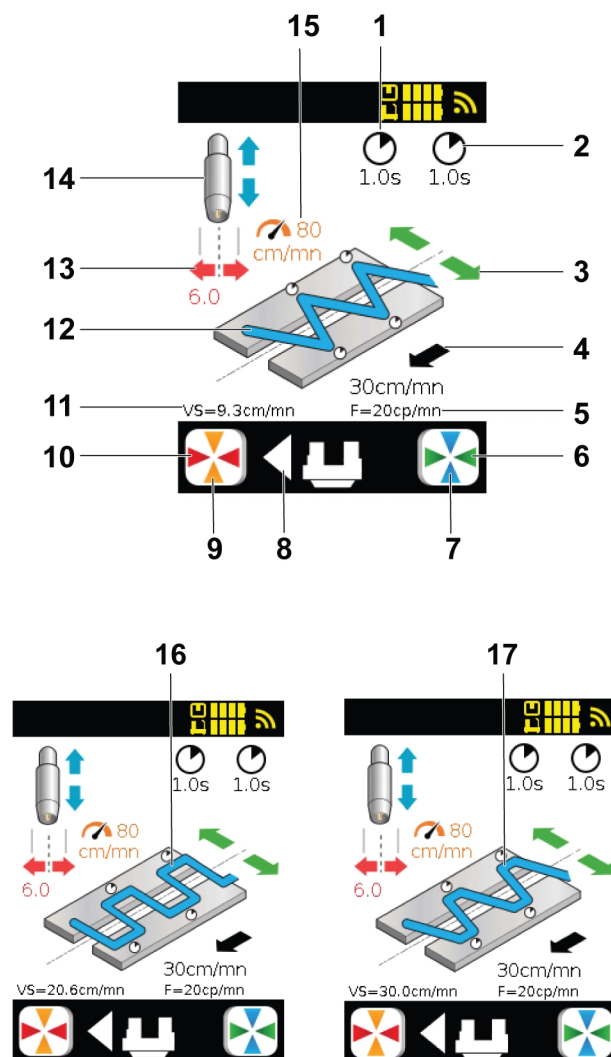

Three different pages depending on the type of welding selected: "triangle step" (12), "square step" (16) or "trapeze step" (17). Only the welding flow chart changes in the different displays.

- **Welding flow chart (12), (16) or (17):** for displaying the type of welding underway.

- **Direction of movement of the carriage (8):** for displaying the direction that the carriage is moving in, depicted with a triangle. Green arrows moves the center of oscillation for welding torch.
- **Orange arrows (9):** for modifying the orange element around the welding flow chart (15): increases or decreases the oscillator speed.
- **Red arrows (10):** for modifying the red element around the welding flow chart (13): increases or decreases the oscillation amplitude.
- **Blue arrows (7):** modifies the blue element around the welding flow chart (14): raises or lowers the welding torch.
The position of the runner is indicated if an axis origin has been taken (see *"Guiding the axes (manual mode)"*, page 39)
- **Green arrows (6):** actions the green arrows around the machine process flow chart (3): moves the centre of oscillation for the welding torch.
The position of the runner is indicated if an axis origin has been taken (see *"Guiding the axes (manual mode)"*, page 39). Direction of movement of the carriage.
- **VS (11):** displays the welding speed.
- **F (5):** displays the oscillation frequency (in number of strokes per minute). With a connected power source, this information is no longer displayed, but welding settings are shown instead.
- **Speed (4):** changes the speed of the carriage's movement.
- **Timer (delay) (1):** for modifying the left timeout (depending on the direction that the carriage is moving in).
- **Timer (delay) (2):** for modifying the right timeout (depending on the direction that the carriage is moving in).

**NOTE!**

As standard, only one timer is visible, and it is the same for both sides. To have both timers, enable "Double dwell time" in settings (see *"Settings"*, page 29)

6.4.7 Plasma cutting

When using plasma cutting, a specific cycle can be used to simplify operation, because the initiation height is not the same as the cutting height.

The torch is primed in contact with the metal sheet and raised to a certain height for initiation (1), then the arc is launched and advanced to this height for a certain time (1). It then drops back down to a cutting height (1).

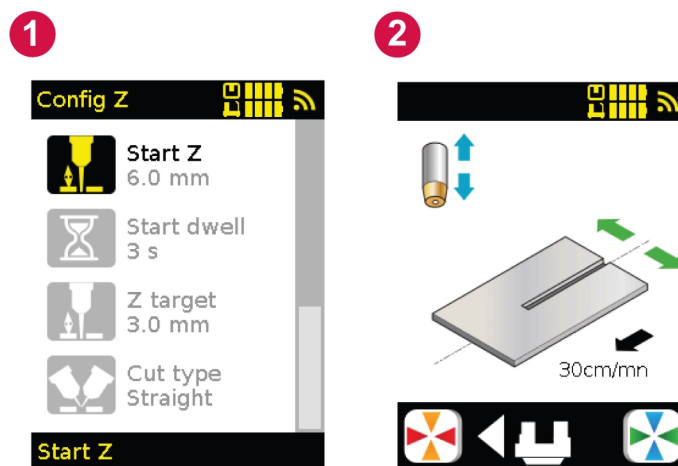

If you are making a chamfer cut, you can select chamfer in "Cut type" (1). This will mean a lower initiation and cutting height, given the angle.

**NOTE!**

When chamfering, it is also possible to leave in straight cut mode and directly select the heights you wish to indicate.

This page can be accessed after selecting "Plasma", (see "*Cycle forms*", page 26). On the main page, you need to change pages to access the "Plasma cut" display.

This page has the same visual and therefore the same description as the "Welding" page without the oscillation settings, see section "*Welding*", page 27.

6.4.8 Settings

This page can be accessed by selecting the "Settings" icon (1) on the "Cycle setup" page.

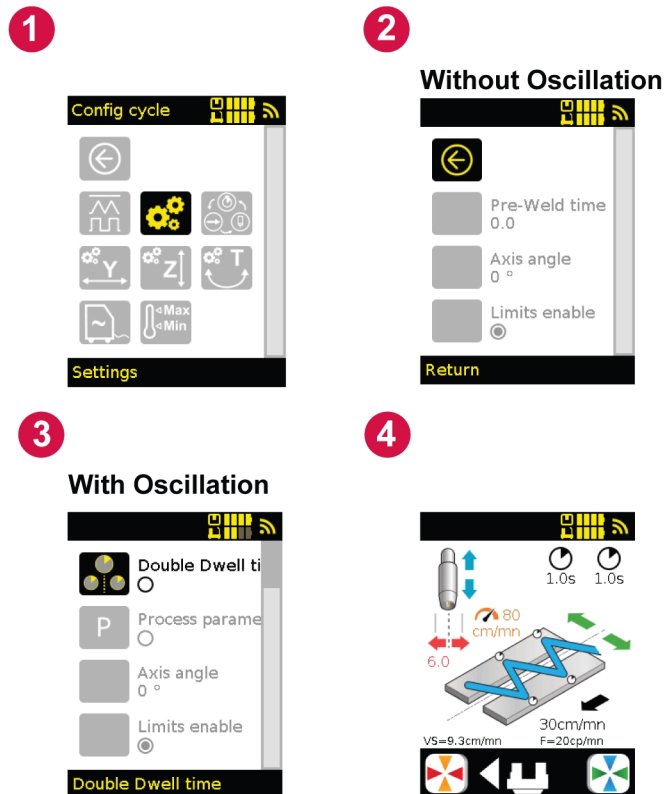

The "Settings" page gives access to the cycle's generic settings.

- **Pre – weld time (2):** used to delay welding in relation to carriage on a continuous seam without oscillation.
- **Axis angle (2):** used to generate a virtual reference for the slides. The movement and oscillation will be within the angle indicated (angle between -90° and 90°).
- **Limits enable (2):** enable user limits to be activated.
- **Double dwell time (3):** activates the possibility of modifying right and left dwell timing independently.

**NOTE!**

For a simple timeout, only the information 1.0s left time delay will display. For a double timeout, the information 1.0s left and right time delay will display.

- **Process settings (3):** another method for configuring oscillation welding.

**NOTE!**

The parameter is active when the pad below the text is black; the parameter is inactive when the pad is white. The “process settings” parameter is inactive, and the “Active limits” parameter is active.

6.4.9 Programming

This page can be accessed by selecting the “Cycle programming” icon (1) on the “Cycle setup” page.

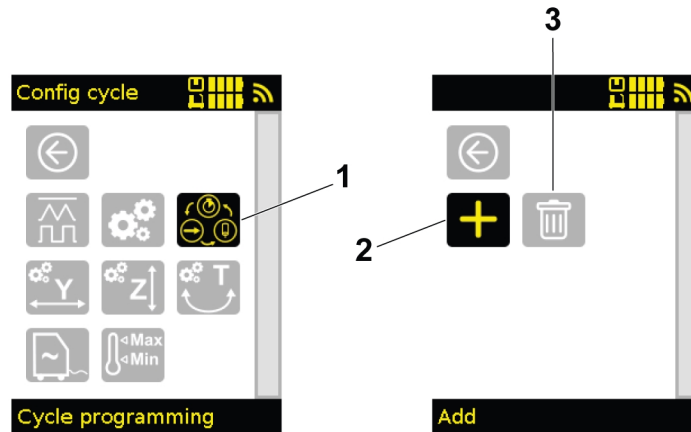

The programming module is developed on a principle of programming in steps (max. 16 steps). To begin programming, a first step must be added by pressing the + (2) to select the first cycle function. A cycle is deleted using the remove all button (3). For example, the sequence below corresponds to:

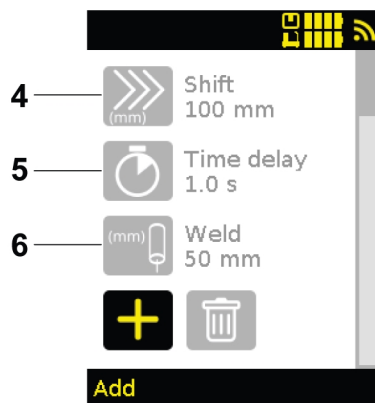

- 100 mm movement, without welding, at a predefined feed speed (cannot be changed in cycle) (4).
- 1 second delay before welding (5).
- 50 mm movement with welding torch n°1, at the speed defined by the “job” (modifiable in cycle by the user if necessary) (6).

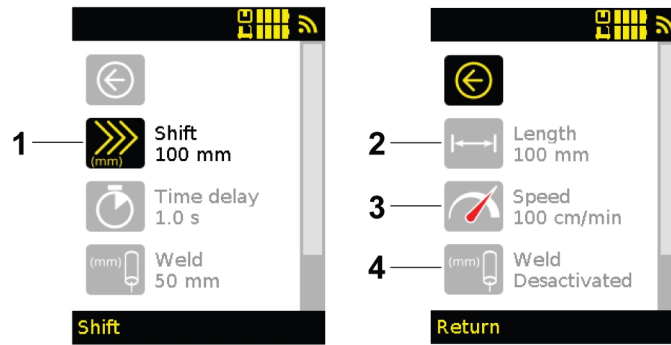

A cycle is made up of a succession of stages corresponding to a predefined function. Each stage selected requires settings as described in this paragraph.

- **Shift (1):** the carriage moves along the defined length (2) at the defined speed (3) with or without a welding arc (4).

NOTE!
If welding is activated, the carriage speed will be fixed and cannot be adjusted during the cycle. To change it during the cycle, select a “Welding” function.

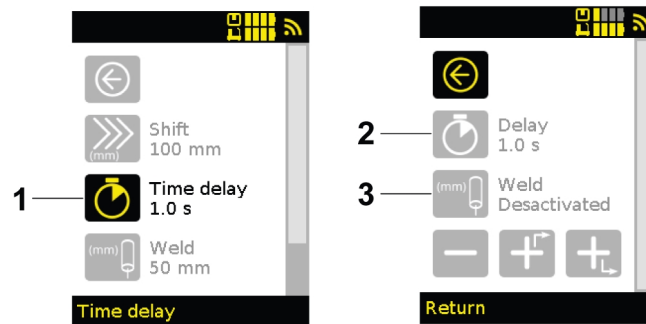

- **Time delay (1):** the carriage is stopped for the set period of time during this step (2) while activating or deactivating the welding (3).

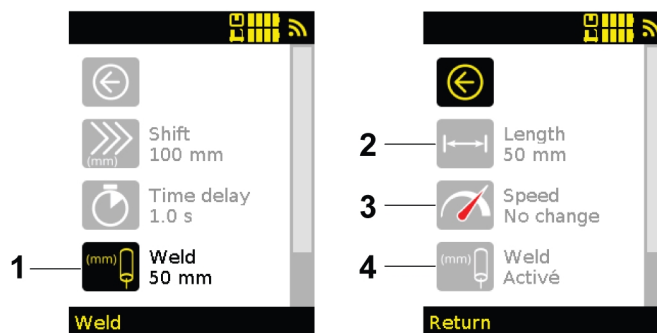

The welding function is used to set the length of the weld bead to be produced with the selected torch (by default torch n°1).

- **Welding 1 (1):** The carriage moves along the defined length (2) with lit welding arc for torch n°1 (4).
- **Speed (3):** “No change” can be selected, in which case the speed can be adjusted using the dial. If a value is set, this speed will be automatically at the start of welding but can be modified afterwards.

**NOTE!**

The trigger cable must be connected.

If the carriage is fitted with two trigger connections on the turret, it is possible to differentiate the activation of the two torches. “Welding 1” for the left-hand socket, “Welding 2” for the right-hand socket or “Welding 1+2” for both simultaneously.

Other configurations can be selected if a second torch is associated with the equipment and connected via a second trigger cable:

- **Welding 2:** the carriage moves along the defined length (2) with lit welding arc for torch n°2. The trigger cable must be connected for torch n°2. This is for discontinuous welding alternating with mounting two torches.
- **Welding 1 + 2:** the carriage moves along the defined length (2) with lit welding arc for torches n°1 and n°2. The trigger cable must be connected for torches n°1 and n°2.

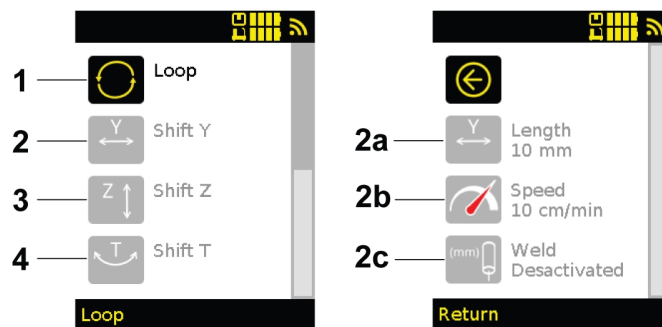

It is possible to add additional functions to the axes connected to the equipment and repeat the cycle.

- **Loop (1):** end of the program step which activates a repeat function. You simply need to set the number of repetitions of the cycle. If the value is 0, loop is infinite until the cycle is voluntarily stopped.

**NOTE!**

By default, the cycle ends at the end of the last stage if loop back is not active.

- **Shift Y (2):** the torch moves along the defined length (2a) along the linear Y axis, at the defined speed (2b), with or without a welding arc (2c).
- **Shift Z (3):** the torch moves along the linear Z axis, over the set length, at the set speed and with or without a welding arc.
- **Shift T (4):** the torch moves along the angular T-axis, at the set angle, at the speed and with or without a welding arc.

A programme can be modified by deleting or inserting a step in a cycle. Select a cycle stage and then select the icons at the bottom of the page.

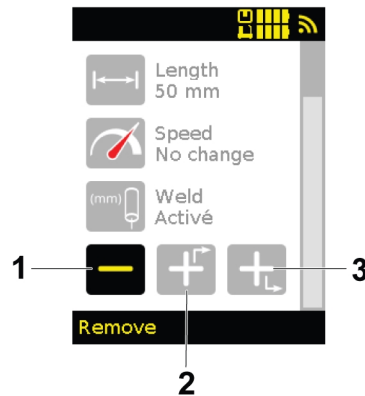

- **Delete (1):** the step selected.
- **Add before (2):** the selected step a new function. You then simply need to set the settings for that stage before returning to the cycle creation page.
- **Add after (3):** the selected step a new function. You then need to set the settings for that stage before returning to the cycle creation page.

6.4.10 Connected axis settings

These pages can be accessed by selecting the “Transverse Axis Config” icon (1) to display the “Y Config” page, the “Vertical Axis Config” icon (3) to display the “Z Config” page and the “Angular Axis Config” icon (6) to display the “T Config” page (identical to the “Y Config” page), from the “Cycle Config” page.



- **Y oscillation (2) / T oscillation:** activates or deactivates Y linear oscillation or T pendulum oscillation.
 - If activates: the oscillation settings can be modified.
 - If deactivates: the axis is considered to be an electric runner and only the position can be modified.

**NOTE!**

Deactivate an unused oscillation to simplify the MMI.

Activation is possible if a Y runner and a T pendulum oscillator are present. If there is only one axis, it is automatically active when an oscillation shape is selected.

- **Y axis inverted (2), Z axis inverted (4) or T axis inverted:** inverts the direction of the axis movement controls. In standard mode left and right for the Y and T axes are defines according to the direction that the carriage is moving in. for the Z axis, the up arrow raises the mount, and the down arrow lowers the mount.

**NOTE!**

This is only displayed if a linear electric runner is connected.

- **Centre step (2):** increment per pulse. A single impulse advances it by 0.1 mm.
- **Position step (4):** increment per pulse. A single impulse advances it by 0.1 mm.
- **SOC (Stick-Out Control) (4):** used to activate or deactivate the Z axis servo control. In TIG, it is written AVC.
- **Target value (5):** selection of the servo control target value. If the value is 0, the target value is set automatically by measurement at the start of the arc. If the value is greater than 0, then this is the target value setting.
- **Asv. Type (5):** selection of servo type.
Step: Pressing the up and down buttons on the Z slide during welding lets users change the target value by 1A (or 0,1V in TIG).
Jog: Pressing the up and down buttons on the Z runner during welding lets users directly change the position of the Z runner, which will be the new target value.
- **Pre-ACQ time (5):** used to define a time (in seconds) before the start of the Z servo. Corresponds to pre-gassing and arc stabilisation.

The settings are displayed as checkboxes. If there is a black dot, the setting is active.

**NOTE!**

Other servo settings and the configuration of the communication box are accessible in the hidden menus.

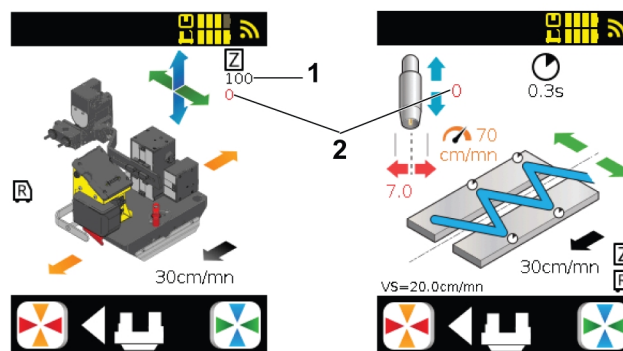

- **100 (1):** Target value.
- **0 (2):** Value read in real time. The “Display data direct” variable must be ticked in the hidden menu.

**NOTE!**

If you're using a straight pass, the value in red is the actual value. If the pass is oscillating, the value is averaged over a period and then displayed.

6.4.11 Limits

This page can be accessed by selecting the “Limits” icon (1) on the “Cycle setup” page.



NOTE!

This page is useful for staying within the ranges of a DMOS.

For the limits to be active and for the limits logo to be visible, the box must be ticked in the settings tab.

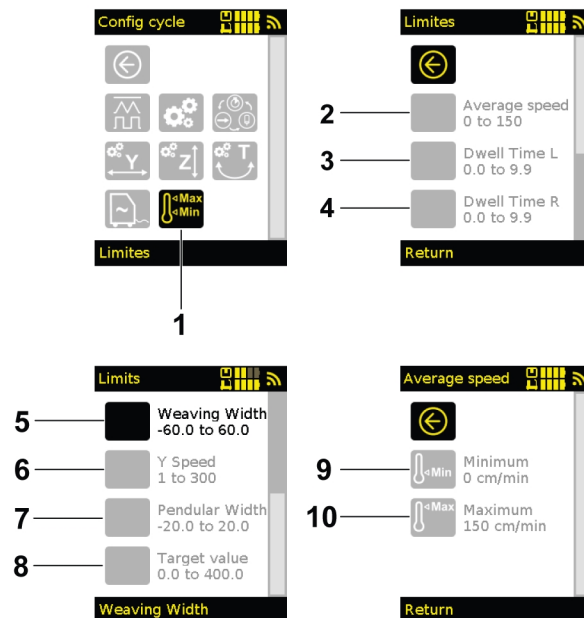

- **Average speed (2):** used to select a minimum (9) and a maximum (10) for the movement speed value adjustable by the operator.
- **Dwell time L (3) and Dwell time R (4):** used to select a minimum and maximum value for left (L) and right (R) time delays when oscillation and double time delay are activated.
- **Weaving width (5):** used to select a minimum (9) and a maximum (10) value for the oscillation amplitude.
- **Y speed (6) and Pendulum width (7):** with communication box connected, you can select a minimum and maximum for your welding settings (not possible with all power sources).
- **Target value (8):** with a communication box or an analogue box connected, if the slaving function is ticked, this is used to select a minimum and a maximum for the servo target value.

6.4.12 Origin resets

This page can be accessed by selecting the “Origin” icon (1) in the menu.

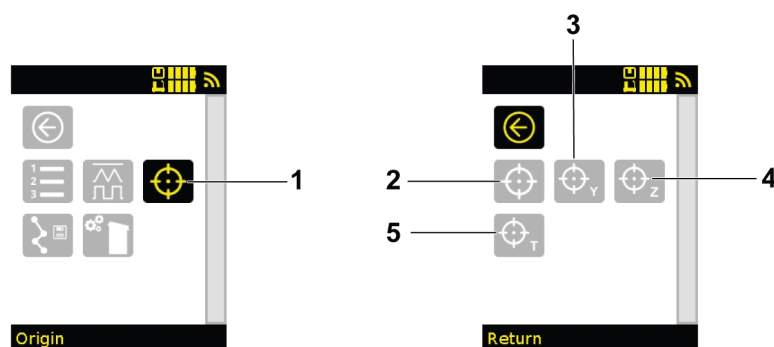

This menu is for resetting all of the axes (2) or a single axis (3, 4 and 5) on the carriage to the origin position.

At the end of the reset, the Y linear oscillator (3) and the T pendulum oscillator (5) are centred in the middle of their travel. The Z electric runner (4) returns to the previous position in order to limit the risk of collision.

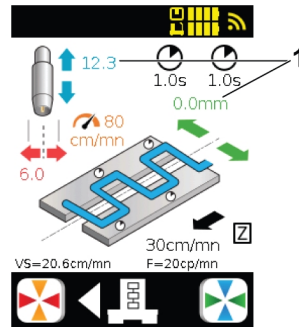

Once the axis has been reset, the position value for the axis travel is displayed in millimetres next to the corresponding arrow on the welding display (1).

6.4.13 Joint teaching

This page can be accessed by selecting the “Save trajectory” icon (1) in the menu.

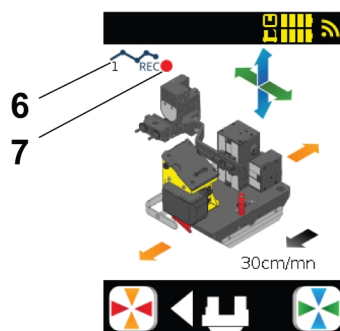
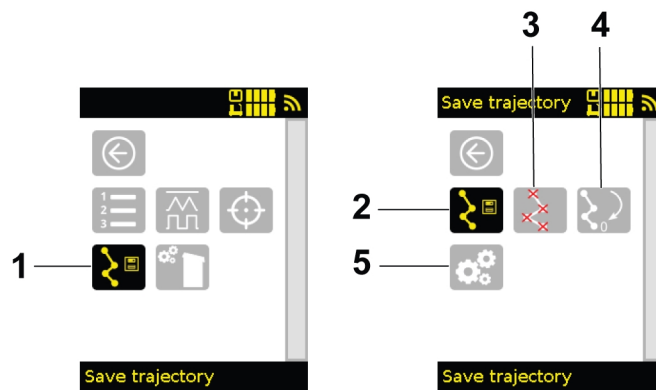

This page enables the carriage to learn a series of points to define a path to follow (welding joint, for example). A linear interpolation is carried out between the points.

Icon (2): gives access to the points learning page:

The “REC” logo appears at the top-right of the screen (7). Using the arrows and the feed and positioning axes, move to the first point to be taught. Press the button at the top right of the control (factory setting) to confirm the point.

NOTE!
Points are YZT coordinates for an X position, rail or track data.

Offset:

- It is possible to apply offsets to the trajectory before starting a new weld (in multipass welding, for example): the offset will be applied to all the points on the trajectory.
- Offset can also be applied during welding.
- Offset can be applied in any direction (YZT).

NOTE!
It is possible to save points in any order or to add to a previously learned trajectory: the points are automatically reordered in the order in which the distance travelled between two points is shortest.

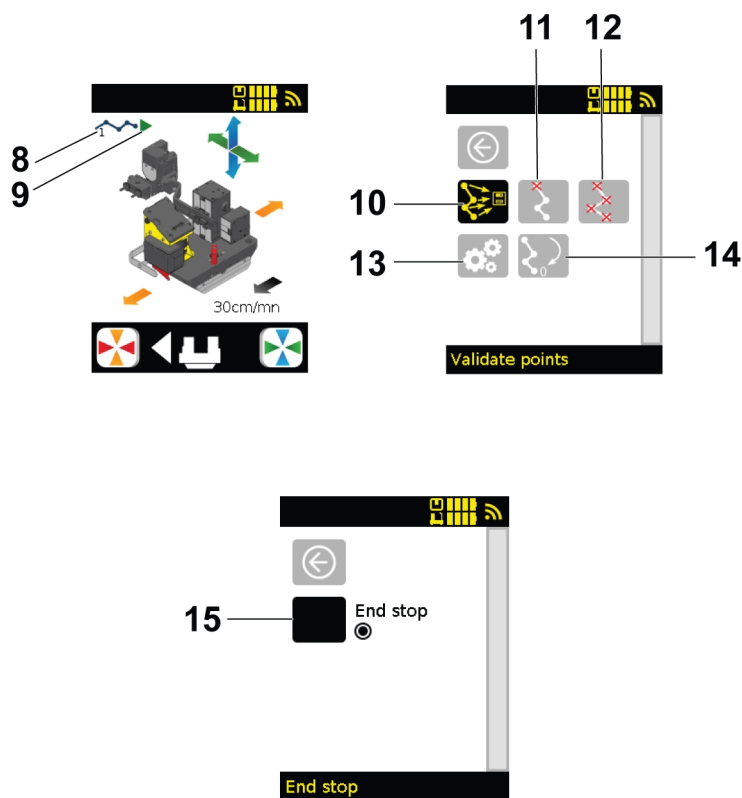

Repeat to validate several points.

The number of points validated appears at the top-right of the screen (6).

Icon (10): validate all the points learned. At the top-right of the screen, the “REC” logo (7) is replaced by a green arrow (9), and the number of learned points appears (8).

Icon (11): delete the last point learned.

Icon (12): delete all the points.

Icon (14): go to the first defined point.

Icon (13): used to access the page for the option to stop welding at the end of the trajectory.

Icon (15): check or uncheck the option to stop welding at the end of the trajectory.

NOTE!
Points and paths may not retain their position after the truck is restarted.

In learning mode, you can configure the top two buttons (1 and 2) on the remote control by pressing and holding the button you wish to configure. Once the button has been pressed and held, the screen offers a number of possible functions:

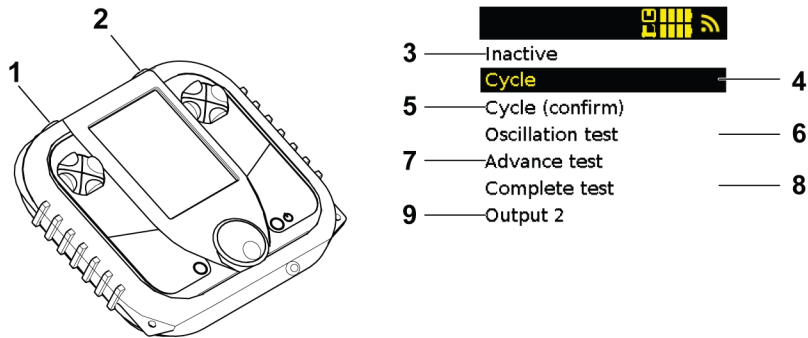

- **Inactive (3):** makes the button inactive.
- **Cycle (4):** cycle start.
- **Cycle (confirm) (5):** cycle start with a double press (within 2 seconds). It is recommended when connecting a torch to the carriage with the trigger cable.
- **Oscillation test (6):** starts oscillation only, with no carriage movement and no arc lit (if triggered).
- **Advance test (7):** starts carriage advance only, with no oscillation and no arc lit. For example, to test cycle programming.
- **Complete test (8):** starts feed and oscillation without arc on.
- **Output 2 (9):** simulates a second output (specific case).

NOTE!
If learning mode is not activated, the buttons are set differently.

6.4.14 Machine configuration

This page can be accessed by selecting the “Machine configuration” icon (1) in the menu.

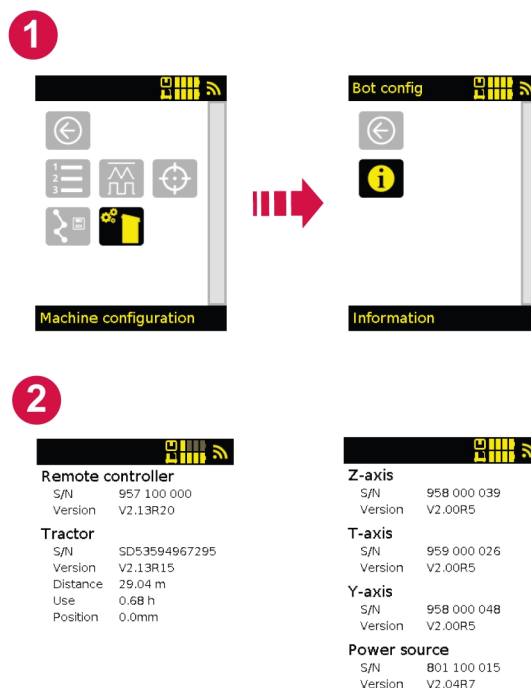

This page (5) displays the serial number and version of each component installed on the carriage (5) at the end.

**NOTE!**

The start of the version number (before the R) between a carriage and a remote control must be identical to be compatible; if the incompatibility message appears, you need to update both the carriage and the remote control. For example: V2.01R1 and V2.01R4 are two compatible versions.

This page (5) also displays the distance travelled and the time that the carriage has been in use.

6.4.15 Guiding the axes (manual mode)

This page is accessible by pressing the button on the remote control.

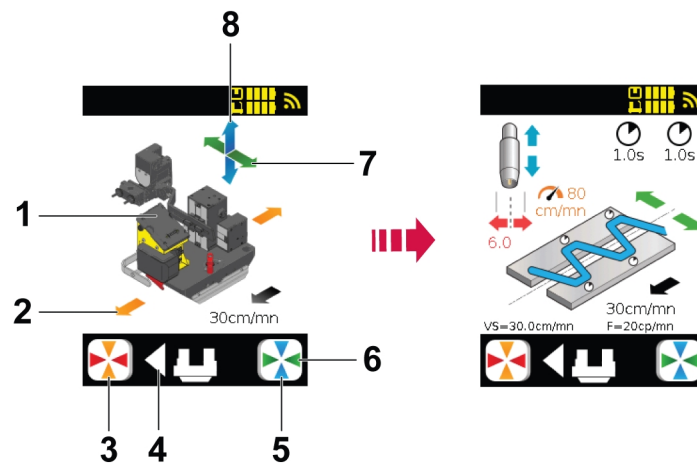

- **Machine process diagram (1):** displays the carriage.
- **Direction of movement of the carriage (4):** for displaying the direction that the carriage is moving in, depicted with a triangle.
- **Orange arrows (3):** actions the orange arrows around the machine process flow chart (2): moves the carriage forwards or backwards.
- **Blue arrows (5):** actions the blue arrows around the machine process flow chart (8): raises or lowers the tool using the Z linear electric runner.
- **Green arrows (6):** actions the green arrows around the machine process flow chart (7): deploys or retracts the tool using the Y linear electric runner.

The control page for positioning the carriage and axes without welding.

This flow chart also shows which accessories are connected and recognized by the carriage.

When three accessories are connected to a carriage, and the carriage is controlled with a two-button multi-directional remote control, you must then change pages using the button to alternately control the position of the linear Y oscillator and the T pendulum oscillator using the coloured arrows.

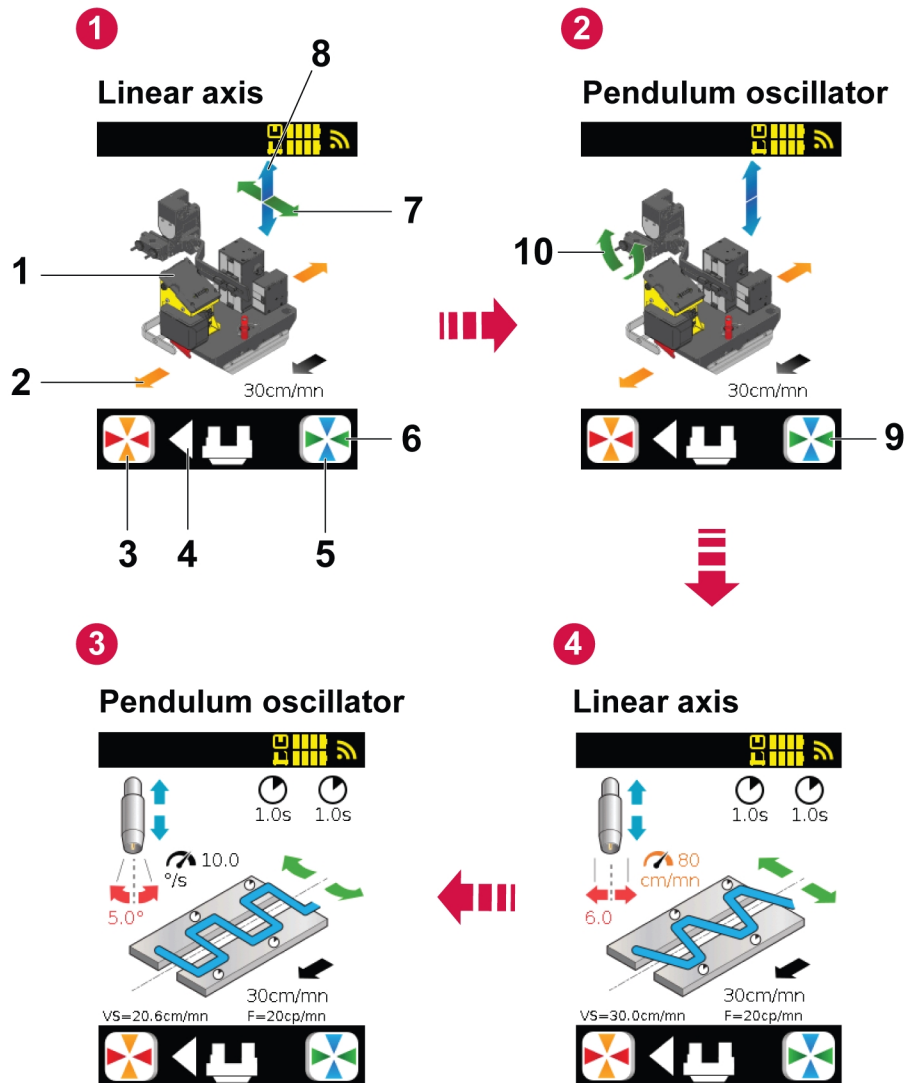

- **Machine process diagram (1):** displays the carriage.
- **Direction of movement of the carriage (4):** for displaying the direction that the carriage is moving in, depicted with a triangle.
- **Orange arrows (3):** actions the orange arrows around the machine process flow chart (2): moves the carriage forwards or backwards.
- **Blue arrows (5):** actions the blue arrows around the machine process flow chart (8): raises or lowers the tool using the Z linear electric runner.
- **Green arrows (6):** actions the green arrows around the machine process flow chart (7): deploys or retracts the tool using the Y linear electric runner.
- **Green arrows (9):** actions the green arrows around the machine process flow chart (10): directs the tool using the electric T pendulum oscillator.

6.4.16 User functions

This function makes the cycle configuration pages accessible only to certain people and only allows operators (users that have not logged in) to access Jobs opening (1), Resets (2), path recording (3) and carriage information (4). This function can be turned on or off in the advanced carriage configuration menu (see *"Advanced carriage configuration"*, page 43).

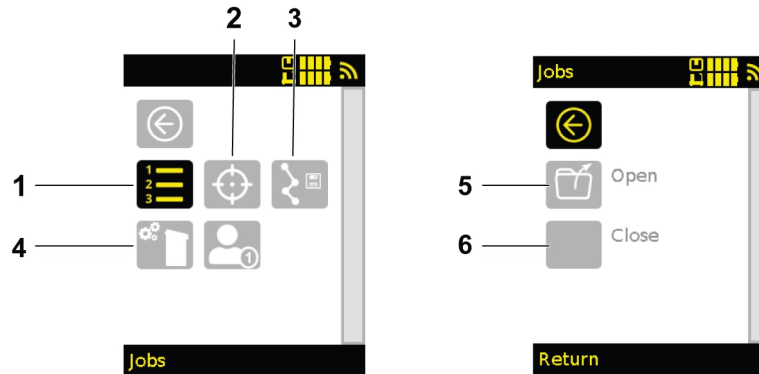

In the “Jobs” tab (1), you can only open (5) or close (6). It is not possible to save, delete or access archives.

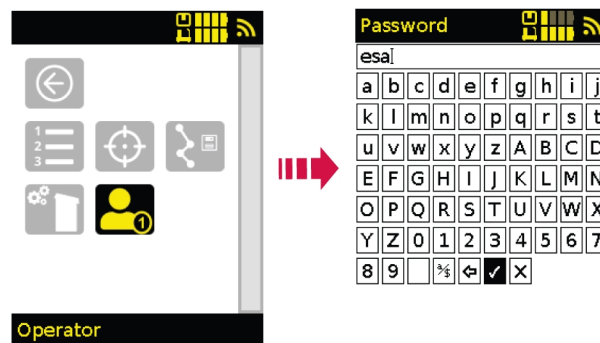

To access the rest, click on the character. A numeric keypad appears, then enter the “esa” code and confirm. This switches you to “Supervisor” mode.

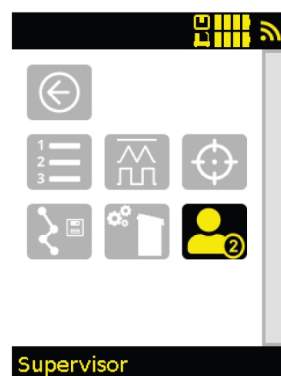

To return to the previous mode, click on the character.



NOTE!

If the carriage or remote control gets turned on or off, the system automatically switches to operator mode.

6.5 Starting up, pairing and turning off the remote control

6.5.1 Starting up and turning off

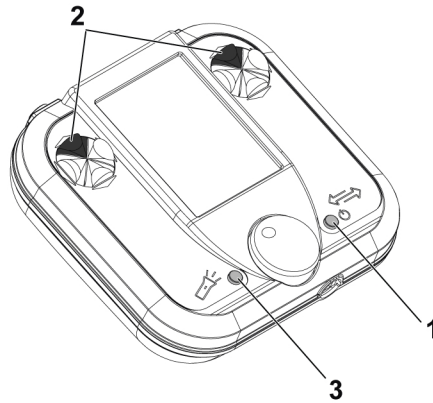

Starting up the remote control

- 1) Press and hold the start button (1) to turn the remote control on.

Turning the remote control off

- 1) If the carriage is powered down, the remote control can no longer communicate with it. After the waiting period, the remote control automatically turns off.



NOTE!

You can force stop it by simultaneously pressing the two buttons (1) and (3).



WARNING!

If the machine becomes unstable, the remote control can be used to force it to stop moving.



WARNING!

If the remote control is turned off during a cycle, the cycle will stop. You can also turn the remote control off and keep the carriage on, which will drain the carriage battery.

Always check the LED on the carriage power supply button (1).

6.5.2 Pairing the remote control

Only do this the first time you use a remote control together with a carriage, when using a new remote control or a new carriage, or when using a remote control from another carriage.

- 1) Once the screen comes on after the remote control is started up, press the two top arrows (see "*Starting up and turning off*", page 42) to launch the automatic pairing procedure with the carriage.
- 2) Place the remote control on the base of the carriage to pair them.

- 3) After that, each time the remote control is turned on, it will be directly paired with its carriage.

**NOTE!**

Pairing the remote control overwrites the last remote control pairing. No data is lost as it is all stored in the carriage.

6.5.3 Setting up the buttons

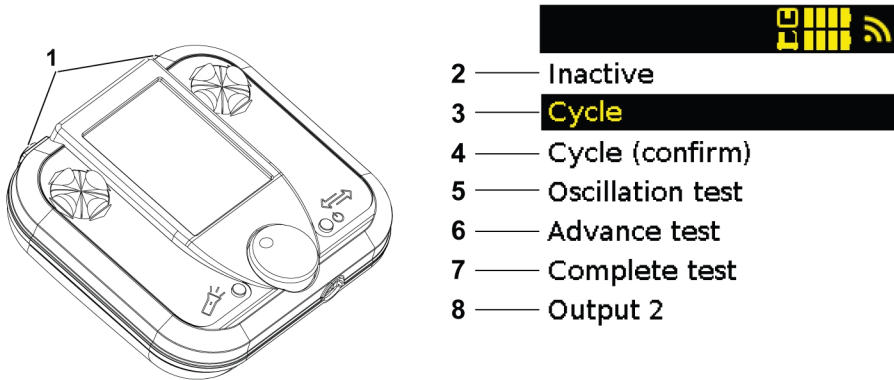

- 1) To access this menu, press and hold the button you wish to set for at least 5 seconds (1).

- **Inactive (2):** makes the button inactive.
- **Cycle (3):** cycle start.
- **Cycle (confirm) (4):** cycle start with a double press (within 2 seconds). It is recommended when connecting a torch to the carriage with the trigger cable.
- **Oscillation test (5):** starts oscillation only, with no carriage movement and no arc lit (if triggered).
- **Advance test (6):** starts carriage advance only, with no oscillation and no arc lit. For example, to test cycle programming.
- **Complete test (7):** starts feed and oscillation without arc on.
- **Output 2 (8):** simulates a second output (specific case).

6.6 Advanced carriage configuration

The advanced carriage configuration menu can be accessed on start up in order to configure special carriage settings.

Accessing the password menu

- When starting up the remote control, press and hold the 2 bottom arrows (1) when the screen displays the visual with the logo, the carriage and the serial number.
- Enter password: esa

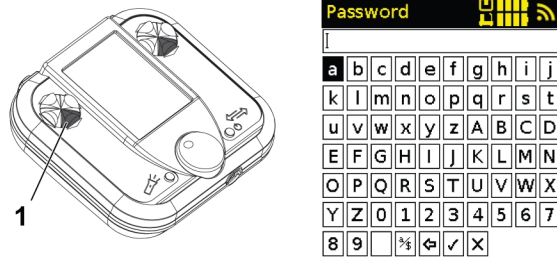

Accessing the hidden remote control menu

1

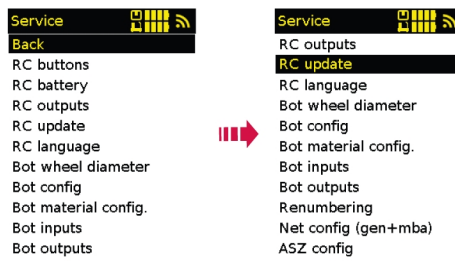

RC buttons

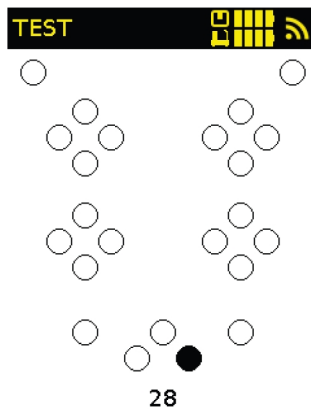

Remote control buttons test menu: to check if a button is blocked (black circle) or if it does not respond (the circle corresponding to the clicked button does not come on). To exit the menu, press the 2 down arrows on the upper cross keys simultaneously.

RC battery



4032mV
24°C
CHRG_OK

Display of information about the remote control battery.

Output RC

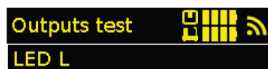

LED L
LED R
Beep
Back

Tests the remote control outputs.

Update RC



UPDATE network

UPDATE
DIRECT-d4-HP M477 Laser
ClickShare-1871776501
WIFI_INVITES
HP-Print-69-Color Laserjet
Back

Access this menu to update the remote control. For full software update instructions see "[Software updates](#)", page 49.

Language RC



Selects the language for the service menu.

Bot config

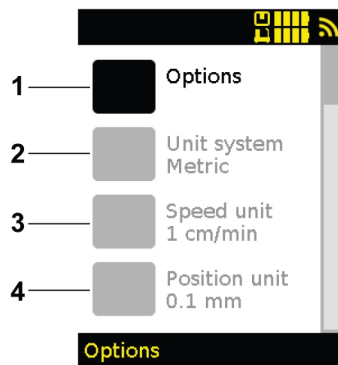

- **Options (1):** activate or deactivate several functions. This makes it possible to clean up the display by removing functions that are not deemed useful. This also makes it possible to use the “Limits” and “Users” functions, which are not present as standard.
- **Unit system (2):** choice of unit used between metric (meter) and imperial (inch).
- **Speed unit (3):** speed increment selection.
 - In metric: selection of 0.1 or 1 cm/min.
 - In imperial: selection of 0.05, 0.1 or 1 inch/min.
- **Position unit (4):** selection of runner position feedback accuracy (displayed on the POM oscillation page).
 - In metric: only 0.1.
 - In imperial: selection of 0.005 or 0.01 inch.

Equipment configure bot

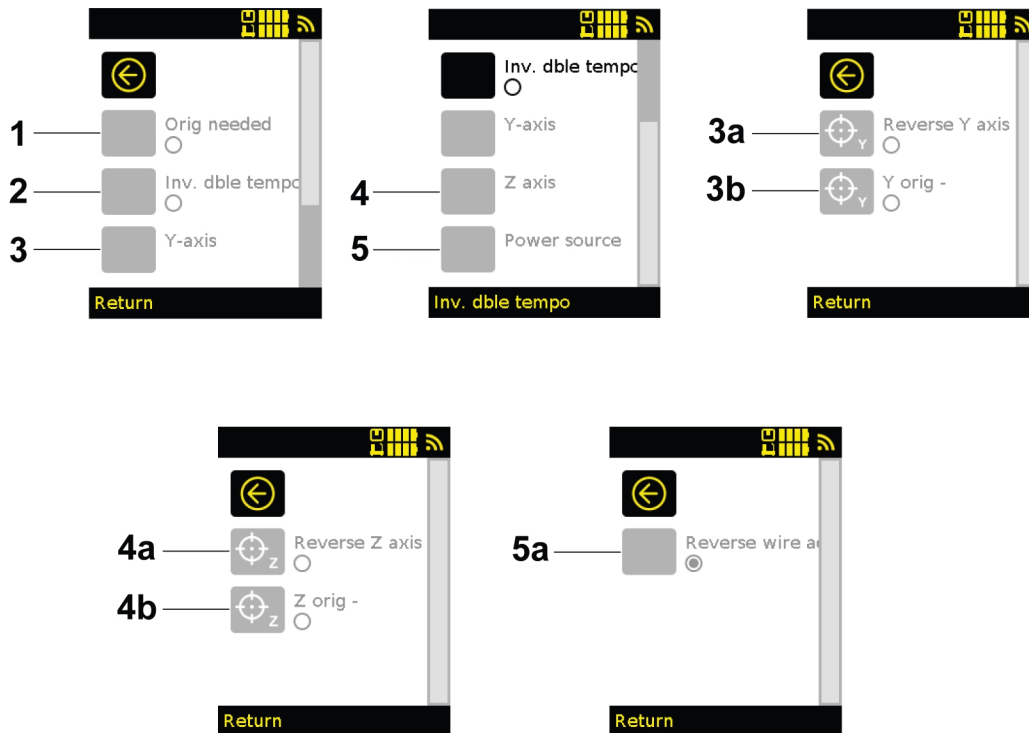

- **Origin needed (1)**: requires original connection at start-up and blocks cycle start-up if not done.
- **Inv. Dble tempo (2)**: inverts the position of the two timers on the oscillation display to double time delay.
- **Y axis (3) and Z axis (4)**: Reverse Y axis (3) and Reverse Z axis (4) are useful if the slides are used in specific configurations where they are not mounted on a carriage. This allows you to put them back the right way round if they have been fitted upside down. To check this, uncheck "Reverse Y axis" and "Reverse Z axis" in this menu and in the menu and then check that pressing the movement buttons moves the slides in the right direction.
- **Y orig - (3b) and Z orig - (4b)**: used to reverse the direction of the original connection. Useful if there is a risk of the runner coming to rest in a certain direction.

**WARNING!**

Inverting the orig in z can bring the torch onto the workpiece if it is too close.

- **Power source (5)**: check or uncheck "Inv. wire feed" (5a) reverses the direction of wire feed when the associated buttons on the remote control are pressed (3).

Bot input

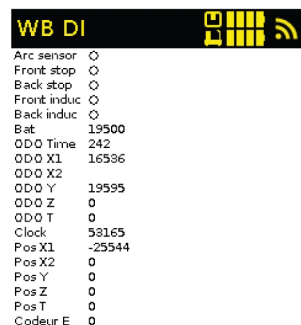

Display of information on the carriage and input status.

Bot output

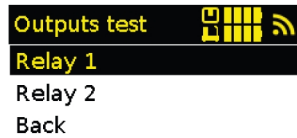

Tests the carriage outputs.

Renumbering

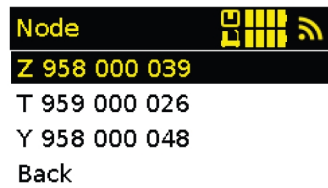

Reassigns a motorised axis. An axis can be set for Y movement (left/right movement on a carriage placed flat) or Z (vertical).

Refer to the serial number located on the axis label.

Net configure (gen + mba)

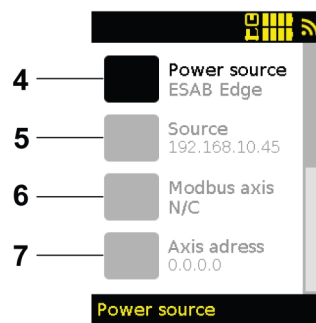
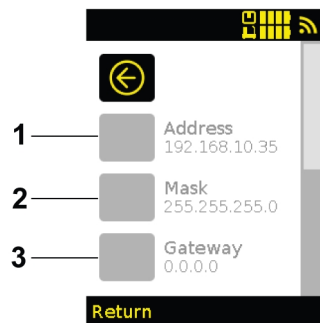

These pages are used to configure the communication box, which is used when a power source or a suitable external axis is connected.

Enter the type of power source (4), then the IP addresses: of the communication box (1), the subnet mask (2), the gateway (3) and the power source (5).

If you have a configurable external axis, enter its type (6) and IP address (7).

ASZ config

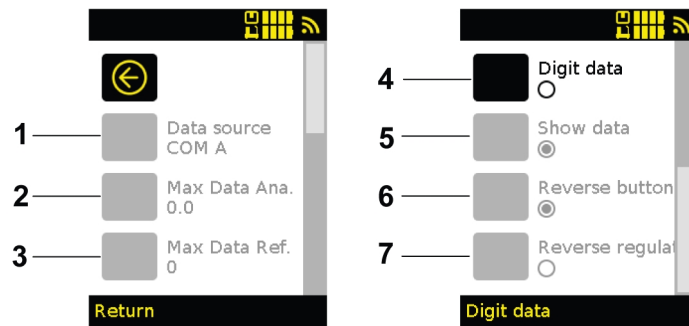

This parameter is only accessible if the servo is active.

These settings are used to define the configuration of the servo system.

- **Source data (1):** used to define the source from which information is retrieved to control:
 - AVC: if the data comes from an analogue box.
 - COM A: if the data comes from a communication box with a MIG power source (servo in Ampere).
 - COM V: if the data comes from a communication box with a TIG power source (servo in Volt).
 - XLR: not currently used.
- **Max Data Ana. (2):** indicates the maximum value of the analogue voltage returned by the power source.
This value is only useful when connected to an analogue box for signal recovery.
- **Max Data Ref. (3):** indicates the value of the real voltage corresponding to the maximum analogue voltage sent by the power source.
This value is only useful when connected to an analogue box for signal recovery.
- **Digit data (4):** tick if TIG is being used (COM A or analogue box with TIG).
- **Show data (5):** displays the value of the servo variable read below the target value on the home page, in real time. In oscillation, this value is displayed at the end of a period and corresponds to the average. This data is displayed in red.
- **Reverse button (6):** when in “step” servo mode, used to reverse the direction of modification of the target value.
- **Reverse regulation (7):** Do not check when regulating with the amperage (MIG-MAG). Check when regulating with the voltage (TIG / Plasma).

6.7 Software updates

6.7.1 Updating tractor

- 1) Turn off the tractor.
 - Press the button to turn off the tractor (see ["Description of the standard tower"](#), page 16) on standard tractor.
 - Press the button to turn off the tractor (see ["Description of the programmable tower and remote control"](#), page 17) on advanced tractor.
- 2) Set up a mobile hotspot configured as:
 - Network name: UPDATE
 - Password: BOOT_BOT
- 3) Ensure the system is active. Press and hold the power button during startup. Continue holding until the lights on the tower or simple interface begin flashing.
 - For standard tractors, see ["Description of the standard tower"](#), page 16.

- For advanced tractors, see "*Description of the programmable tower and remote control*", page 17.

4) Wait until the lights stop flashing.

5) Check on the information screen if the tractor software version has been updated.

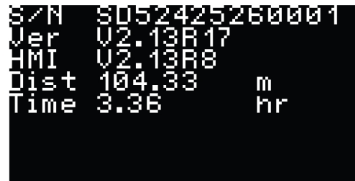

6.7.2 Updating remote control

1) When starting up the remote control, press and hold the 2 bottom arrows (1) when the screen displays the visual with the logo, the carriage and the serial number.

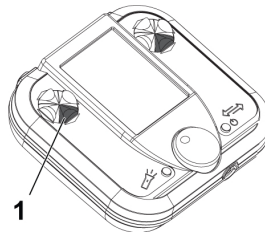

2) Enter the password "esa".



3) Select "RC update" in the menu.

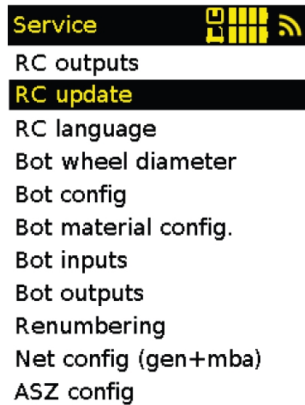

4) Update network:

- If the remote control is connected to the hotspot, press "YES".
- If the remote control is not connected press "NO".



- If the mobile hotspot has been configured as per Step 1, it can be selected directly without requiring a password.
- If no mobile hotspot is available, a local Wi-Fi network may be selected. In this case, the Wi-Fi password must be entered via the HMI interface.

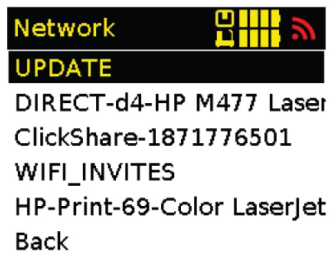

5) When the remote control connects to a network, the update starts automatically.

- 6) Check the Information menu to confirm that the software version has been updated.

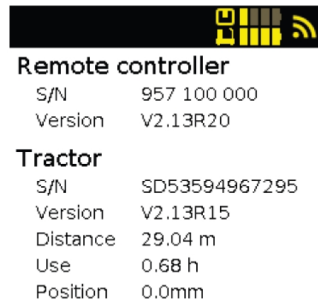

6.7.3 Updating accessory (communication box, axes etc).

- 1) To update accessories, follow the same steps as for updating the carriage. Make sure the accessory is connected to the accessory port during the update.
- 2) After the update is complete, check the Information screen in the HMI to confirm the software version has been updated.

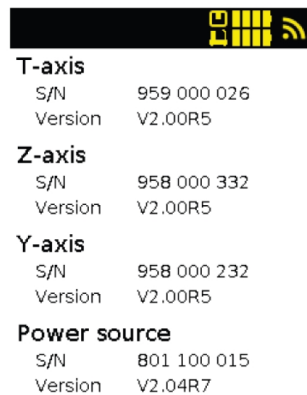

7 MAINTENANCE

**WARNING!**

For repair or after sales service, the equipment must not be returned with a battery that might be defective.

**CAUTION!**

Repair and electrical work should be performed by an authorized ESAB service technician. Use only ESAB original spare and wear parts.

**NOTE!**

Eliminate the welding splatter and regularly clean the remote control magnets.

**NOTE!**

Regularly clean the carriage exterior and the adjustment components. Each time before you insert the battery, clean the mount.

7.1 Periodic maintenance

Every 100 hours of usage

- Clean the carriage and make the adjustment of components
- Clean the lower housing of the mobile base
- Clean the support rollers
- Clean and check the wear on the guide rollers

Every 500 hours of usage

- Clean and lubricate the moving parts
- Check the wear on the moving parts and replace parts showing excessive wear
- Carefully spray dry air on the circuit boards and check the connections

7.2 Rail servicing and replacement instructions

Routine maintenance

- Regularly clean the magnetic terminals using a soft cloth and compressed air.

**WARNING!**

Safety glasses mandatory (risk of projectiles when cleaning the magnetic terminals).

**WARNING!**

Protective gloves mandatory (risk of crushing when handling equipment).

Replacing a magnet

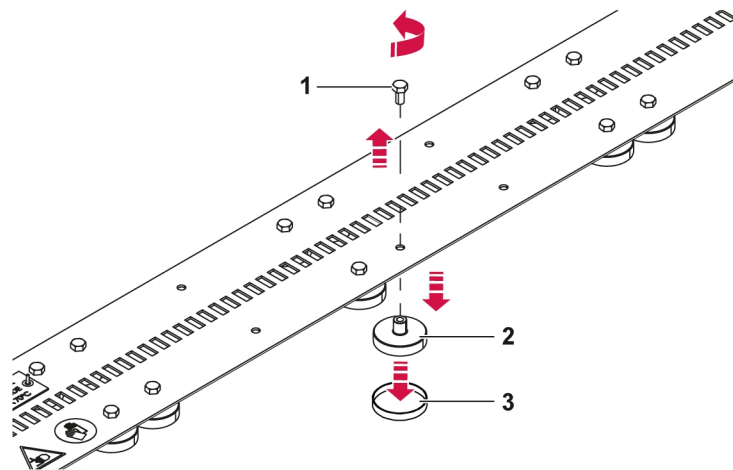

- 1) Clean the rail to ensure that it's free of metal dust and parts.

WARNING!
Safety glasses mandatory (risk of projectiles).

WARNING!
Protective gloves mandatory (risk of crushing when handling equipment).

WARNING!
In the case of a HT rail, wait for the rail to completely cool down before handling (risk of burns).

- 2) Unscrew the bolts (1) to remove the magnet (2).
- 3) Replace the magnet (2).

NOTE!
For a HT rail, replace the magnet with a HT version (with or without cap - depending on its position on the rail).

- 4) Screw the bolts (1) back in to replace the magnet (2).
- 5) Repeat the operation if several magnets must be replaced.

7.3 Replacing rollers

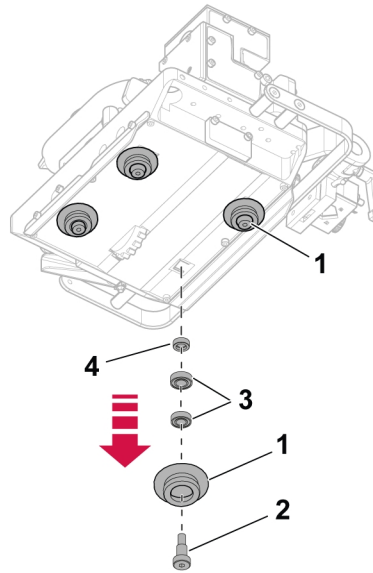

- 1) Unscrew the screw (2) to remove the guide roller (1).



WARNING!

The guide roller is held in place by two bearings (3) and one spacer (4). Make sure you do not lose them during disassembly and put them back in the right order when remounting.

- 2) Repeat the operation to remove the four guide rollers (1).
- 3) Repeat the steps in reverse order to refit them.

8 TROUBLESHOOTING

Perform these checks and inspections before sending for an authorised service technician.

Type of fault	Possible cause	Corrective action
The remote control does not turn on	The remote control battery is drained	Recharge or replace the remote control battery
Axis absent from the screen	The axis is improperly connected, or the cable is defective. Incorrect axis configuration.	Reconnect the axis to a free accessory port or replace the cable.
The remote control will not pair.	The remote control is not associated with the right carriage.	Check that the serial number that is displayed in the remote control search bar corresponds to the one displayed on the carriage information plate.
The arc detector is not working.	The tool mount jaw is mounted backwards.	Properly install the tool mount.

Remote control fault code	Solution
Carriage limit switch warning	If there is a limit switch on the carriage: the fault is displayed when the limit switch is active.
Low battery alert	Recharge or replace the carriage battery.
Runner stop alert (Y or Z)	The fault is displayed when the axis (Y or Z) is at the end stop or something is blocking its movement.
T axis stop alert	The fault is displayed when the T axis is at the end stop or something is blocking its movement.
System fault (X)	Contact after-sales support and report fault number "X".
Remote control connection fault	If the carriage has been configured with the timeout option (cycle interrupted when carriage/remote control connection is lost): the fault is displayed when the remote control is lost.
Version incompatibility	The fault is displayed if the software versions are not compatible: <ul style="list-style-type: none"> carriage/remote control (alternating with remote control connection fault). axis/remote control (alternating with "X" axis fault).
Axis fault (Y, Z or T) absent	The fault is displayed when the axis (Y, Z or T) is disconnected during a cycle.
Motor fault (1 or 2) carriage	The fault is displayed if the feed motor is over-torqued or if the carriage is not reaching its feed speed

9 ORDERING SPARE PARTS



CAUTION!

Repair and electrical work should be performed by an authorised ESAB service technician.
Use only ESAB original spare and wear parts.

The Mech MIG Rail Carriage are designed and tested in accordance with international and European standards **ISO 12100,60204-1, EN IEC 60974-1, EN IEC 60974-5, EN IEC 60974-10**. On completion of service or repair work, it is the responsibility of the person(s) performing the work to ensure that the product still complies with the requirements of the above standard.

Spare parts and wear parts can be ordered through your nearest ESAB dealer, see [esab.com](https://www.esab.com). When ordering, please state product type, serial number, designation and spare part number in accordance with the spare parts list. This facilitates dispatch and ensures correct delivery.

APPENDIX



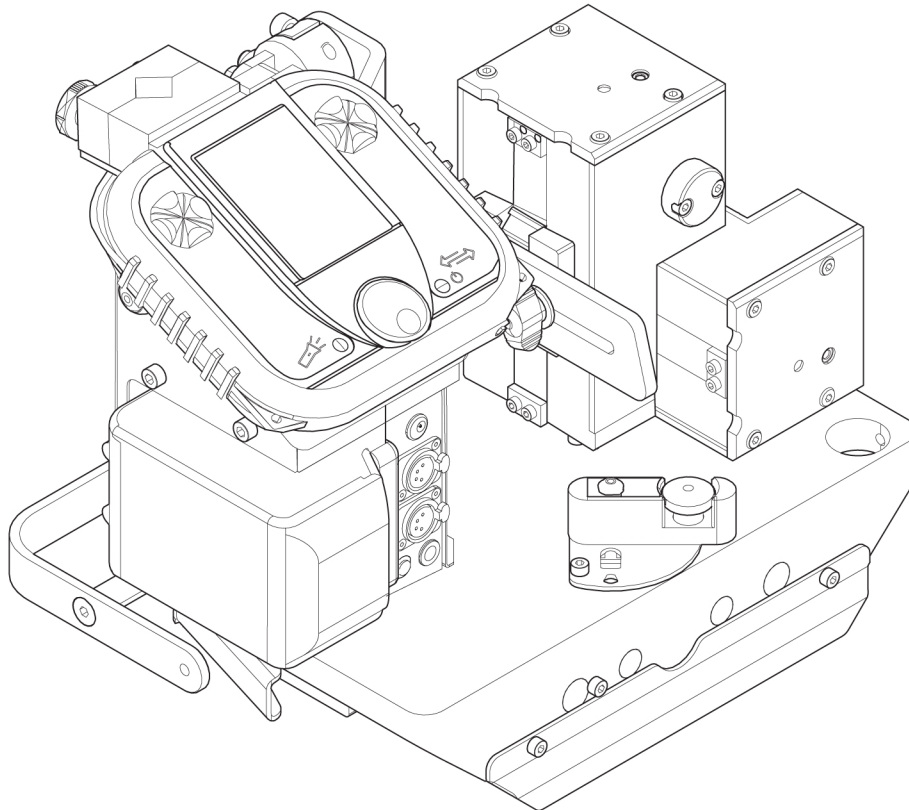

ORDERING NUMBERS



Ordering number	Description
A000 101 099	TRACFINDER RAIL Standard Package
A000 101 100	TRACFINDER RAIL Advanced Package
A000 101 218	TRACFINDER RAIL Advanced+ Package

Technical documentation is available on the Internet at: www.esab.com

ACCESSORIES

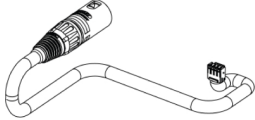
0464 752 434	Connecting bracket - Motorized axis	
0464 752 538	Communication box (Modbus)	
0464 752 540	Big manual slide L 100 mm	
0464 752 552	High temperature torch holder (250°C max)	
0464 752 555	Long arm L 400 mm	
0464 752 556	Extra long arm L 700 mm	
0464 752 560	Angular adjustment arm	
0464 752 588	Power supply interconnection cable L = 600 mm	

APPENDIX

0464 752 592	Standard magnetic flexible track L 1500 mm	
0464 752 593	Half-length magnetic flexible track L 750 mm	
0464 752 594	High Temperature (180°C max) magnetic flexible track L 1500 mm	
0464 752 595	Half-length high temperature (180°C max) magnetic flexible track L 750 mm	
0464 752 604	Stiffened magnetic track L 1500 mm	
0464 752 605	Rail end stop sensors	
0464 752 606	Complete angular torch holder for MIG-MAG	
0464 752 608	Connecting plate – Motorised Y axis – manual Z axis	
0464 752 610	Power supply interconnection cable L = 750 mm	

APPENDIX

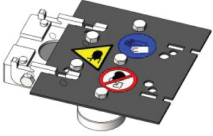
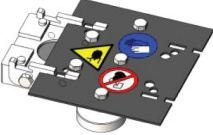
0464 752 613	Additional magnetic end of flexible track	
0464 752 615	Additional high temperature (180°C max) magnet plate	



A WORLD OF PRODUCTS AND SOLUTIONS.



For contact information visit esab.com

ESAB AB, Lindholmsallén 9, Box 8004, 402 77 Gothenburg, Sweden, Phone +46 (0) 31 50 90 00

manuals.esab.com

